

musser

A DIVISION OF CONN-SELMER, INC.

M55G GOLD PRO-VIBE



CONCERT FRAME

MUSSEER

A DIVISION OF THE CONN-SELMER, INC.

Dear Customer,

We at Musser want to thank you for selecting one of our percussion instruments. Generations of **American Craftsmanship**, Knowledge and Pride go into each and every **Musser** product.

In striving to offer the highest quality instruments and service in meeting your musical needs, we ask that you please complete both the registration Form and our Customer Satisfaction Survey.

If you are pleased, **tell everyone**; if you are not, **please let us know. WE WANT TO KNOW!**

Specifications are subject to change without notice as we at Musser continue to improve our products. The information in this manual is intended to be of a general nature only.

Thank you,

All Employees
Musser Division
Conn-Selmer Inc.

ASSEMBLY INSTRUCTIONS FOR THE M-55 PRO VIBE

PARTS LIST

Instrument Frame

1 set of Resonators (Natural and Sharp Scale)

1 set of Bars (Natural and Sharp Scale)

Crossbar and Pedal Assembly

Read all instructions carefully before assembling the instrument.

NOTE: Do not attempt to stand the instrument on its casters without the Crossbar properly attached.

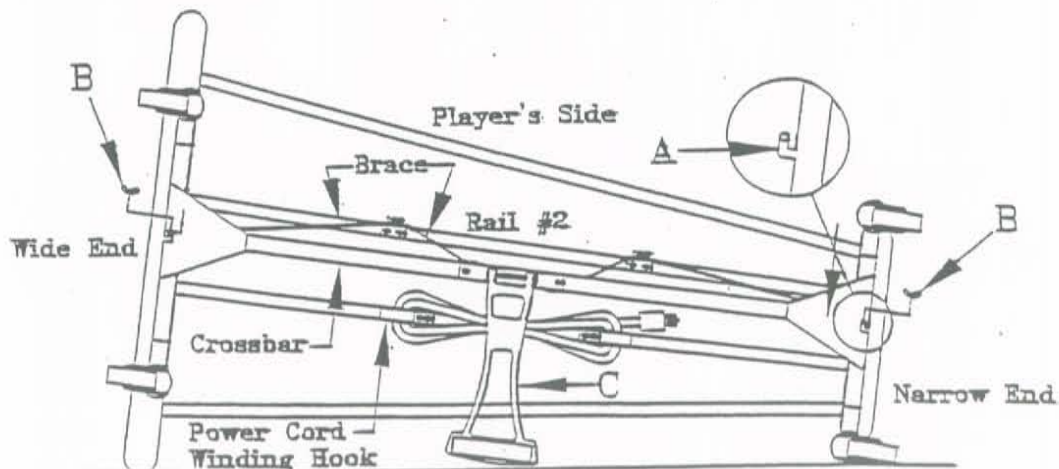

FIG. I
BOTTOM VIEW OF FRAME WITH LEGS OPEN

1. Refer to Figure I. Set the front of the instrument Frame on edge over a rug or several sheets of paper with the wide end of the Frame to your left.

2. Release the Velcro® straps on the underside of the Frame and open the Legs completely.
3. Secure the Crossbar at the wide end first by sliding Slot "A" onto the Stud and under the hand knob at "B". Do the same at the narrow end. Pull the Crossbar down toward the floor so that Slot "A" is secured onto the Studs. Tighten the hand knobs securely.

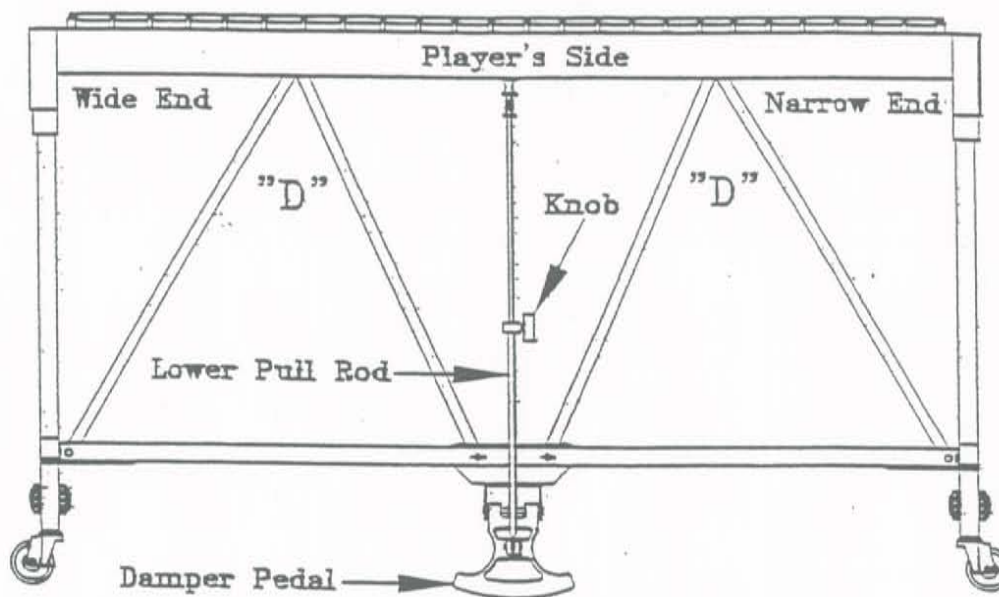

FIG. II

4. Refer to Figure I and II. With the instrument still positioned as in Figure I, fasten all four diagonal braces "D" by swinging each Brace toward the Frame and attaching each one to its corresponding Stud and Wing Nut assembly on the #2 Rail (See Figure I). Tighten the wing nuts securely. The instrument may now be set up in its normal upright position.

5. **Height adjustable feature:**

The height adjustment feature is simple, yet effective, and provides 4" of height adjustment. The Damper foot Pedal is also height adjustable for player comfort.

Note: If this feature is adjusted with the instrument in the upright playing position, it is necessary to have two people complete this task. One person will lift the end of the frame, holding it securely in place, while the other person adjusts and secures the Leg Insert with Caster attached.

Making sure the instrument is safely supported, unscrew the Knob with the through hole and remove the Knob with the Threaded Stud attached. Raise or lower the Frame to one of the four (4) height positions. This is determined by the selection of one of the holes in the Leg Insert with the Caster attached. Replace the Knob, with the Threaded Stud, through the hole in the Leg and tighten this together with the through hole Knob on the opposite side and tighten securely. Repeat this procedure for the other three Caster locations.

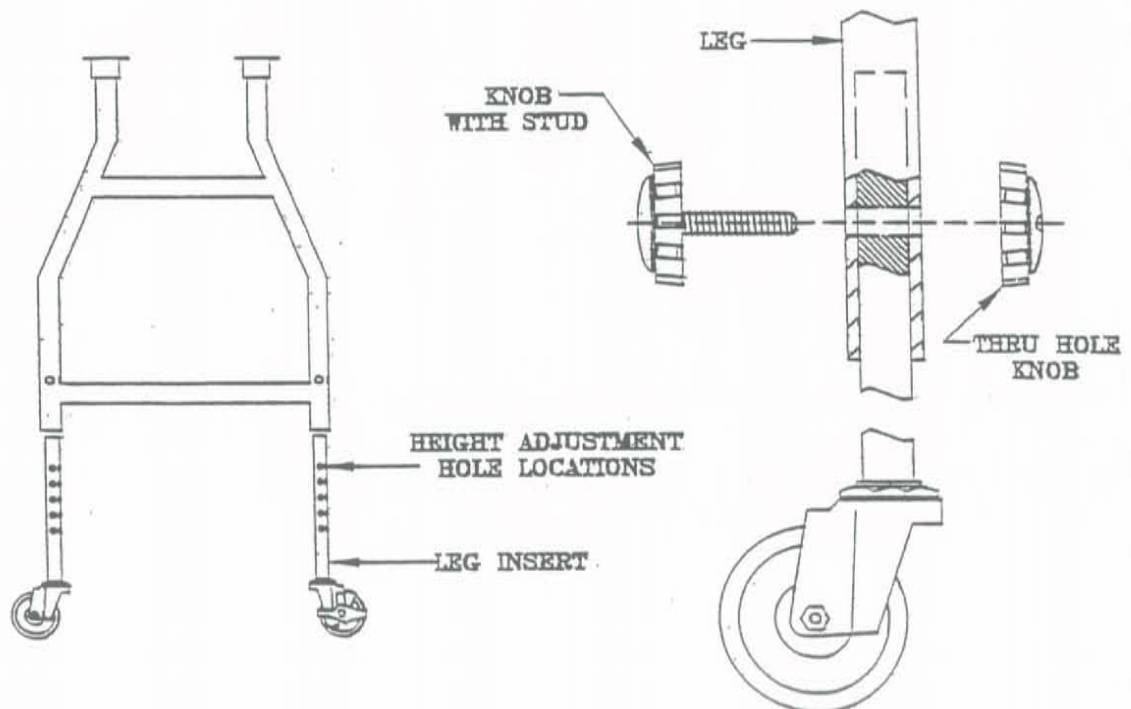

FIG. IV

6. Swivel the Pedal so that it points toward the #1 Rail (Arrow C in Figure I). Refer to Figure V. To attach the Damper Pedal to the Damper Bar: (A) Loosen the hand knob on the Lower Pull Rod. (B) Pull down Spool "E". (C) Hook the Upper Pull Rod into the Eyebolt on the Damper Bar.

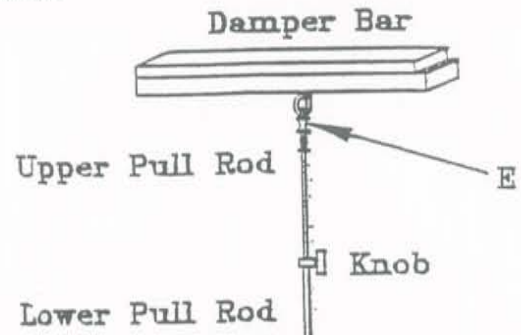

FIG. V

When Motor is used, unwind the Motor Power Cord and plug into a suitable electrical outlet. If the Motor is not being used, or when the instrument is being transported, the Power Cord should be kept wound tight around the Power Cord Winding Hooks on the underside of the Frame. It is recommended the Cord be wound in a tight Figure 8 Pattern as in Figure I.

7. Refer to Figure VI. Place the Natural Scale Resonator under the Frame. Slide the small end of the Resonator into the cutouts on the narrow Frame end. This end of the Resonator should rest inside the Frame End as shown in Figure VII. bring the other end of the Resonator up toward the Frame as shown in Figure VI. Refer to Figure VIII and notice how one of the Resonator Strips passes between the two Rubber Resonator blocks and the other Strip passes between the Rubber Block and the #1 Rail. Center the Strips over the Slots in the Blocks and press them into place. Make certain, when the Resonator Strips are placed in the Slots of the Rubber Blocks, the Resonator is pulled back toward the wide end of the Frame as far as it will go as indicated by Arrow "F". Repeat the same procedure to install the Sharp Scale Resonator.

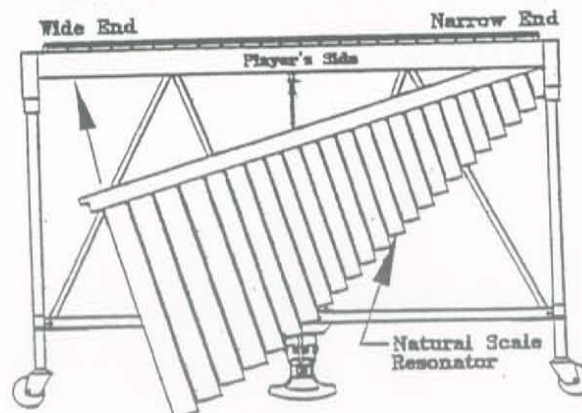

FIG. VI

NARROW END OF INSTRUMENT

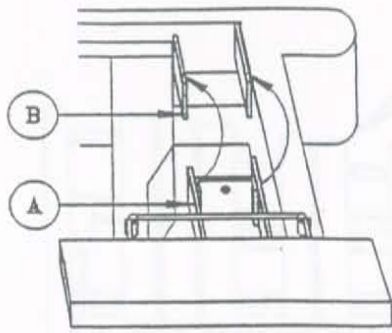

FIG. VII

WIDE END OF INSTRUMENT

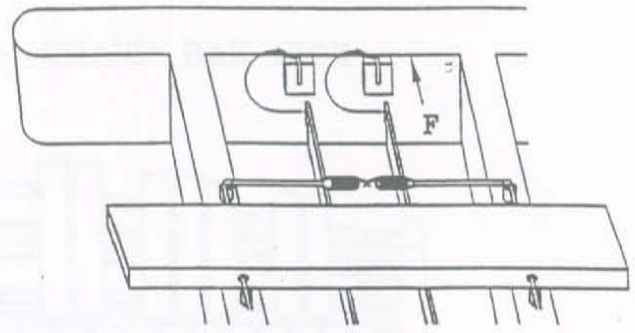

FIG. VIII

8. Refer to Figure IX. To install the Rubber Drive Belt (located at the narrow end of the instrument): (a) Slip the Drive Belt around the Pulley on the Motor. If your model has no motor, start with step b. (b) Slip the Belt around one of the Resonator pulleys. (c) Stretch the Belt by hand and slip it around the other Resonator pulley. Pull the belt by hand to insure it is correctly hooked onto the Resonator Pulleys. Try to align the pulsators evenly by holding onto one pulley while rotating the other.

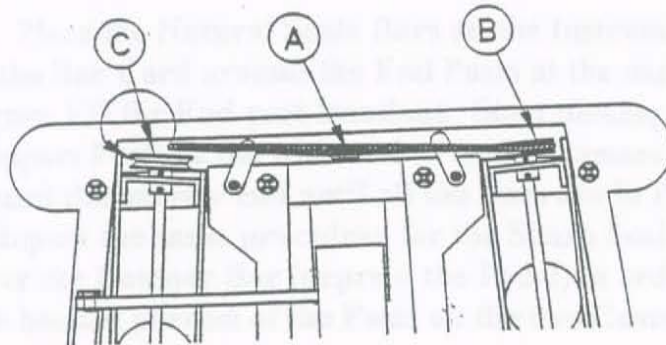

FIG. IX

9. It is very important to remember, when your not using the motor, that the Pulsator Discs be set at a 45 degree angle to achieve the most balanced resonance across the entire keyboard. See Figure X.

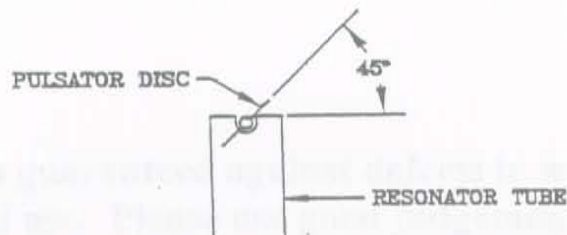
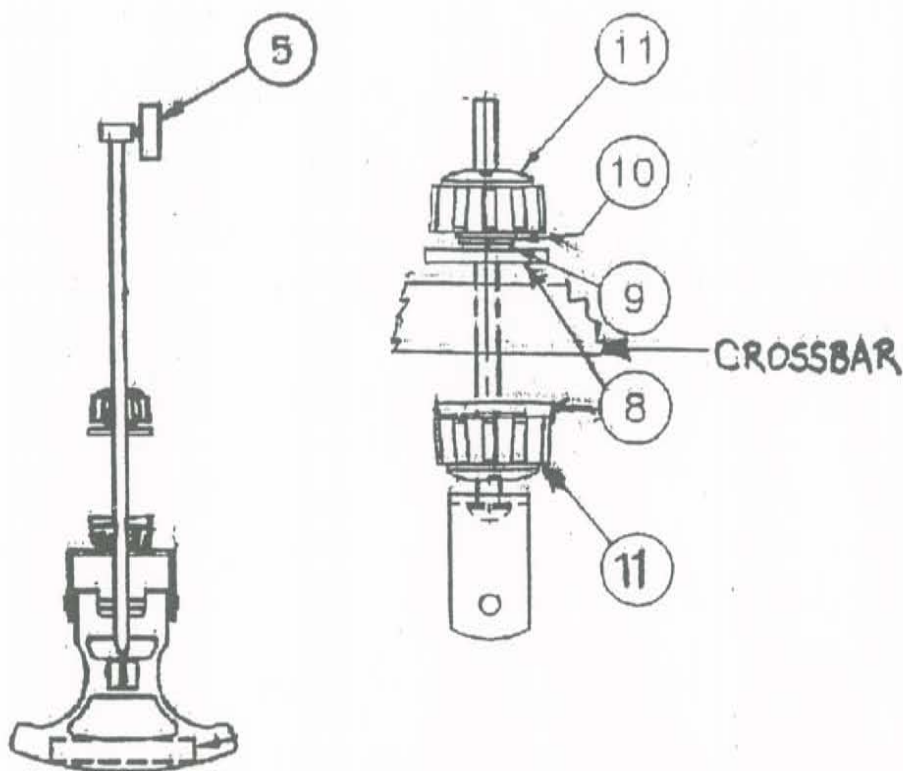

FIG. X

HEIGHT ADJUSTABLE PEDAL ASSEMBLY



| | | | |
|----------|----------|--------------------------------|------|
| 11 | E9784 | KNOB 5/16-18 FEMALE | 1 |
| 10 | E2212 | FLAT WASHER 5/16 | 1 |
| 9 | E2056 | LOCK WASHER 5/16 | 1 |
| 8 | E6440 | WASHER (PIPER) | 2 |
| 7 | E32031 | DAMPER NUT | 1 |
| 6 | E3238 | CUSSION | 1 |
| 5 | E9487 | KNOB 1/4-20 MALE | 1 |
| 4 | E2204 | WASHER (NYLON) | 2 |
| 3 | E3357 | PIN | 1 |
| 2 | E3958 | PEDAL BRACKET ASSEMBLY | 1 |
| 1 | E9496 | PEDAL ASSEMBLY (POWDER COATED) | 1 |
| ITEM NO. | PART NO. | DESCRIPTION | QTY. |

A WORD ABOUT YOUR CASTERS:

Your instrument is equipped with (4) casters that do not use internal sockets in the black aluminum legs for attachment. The casters secure to the leg tube by means of an expandable stem.

The following instructions should be followed for installing and removing the casters. See illustration below.

Note: Make certain that the round, knurled nut at the top of the stem of the caster is tightened against the rubber tube that covers the stem.

The large eight sided nut directly above the ball bearings on the caster controls the diameter of the expandable stem by increasing or decreasing the size of the rubber tubing that covers the stem when the stem is inside the leg tube. Looking at the caster from the bottom, turning the eight sided nut clockwise increases the diameter. Turning the nut counterclockwise decreases the diameter.

TO INSTALL: Slide the stem of the caster all the way into the leg tube. If the stem will not go in, decrease the diameter by grasping the rubber covering the stem in one hand and turning the eight sided nut counterclockwise with the other hand. When the stem is fully inside the tube, **turn the large nut clockwise**, by hand, until it is tight and the stem is secure in the leg. There is no need to over tighten. No tools are required. **(NOTE: If any of the casters ever become loose or fall out, follow the installation procedure and turn large nut on caster a couple extra turns until tight.)**

TO REMOVE: Turn the large nut counterclockwise, by hand, until the caster stem can be pulled out of the leg tube. Again, no tools are required.

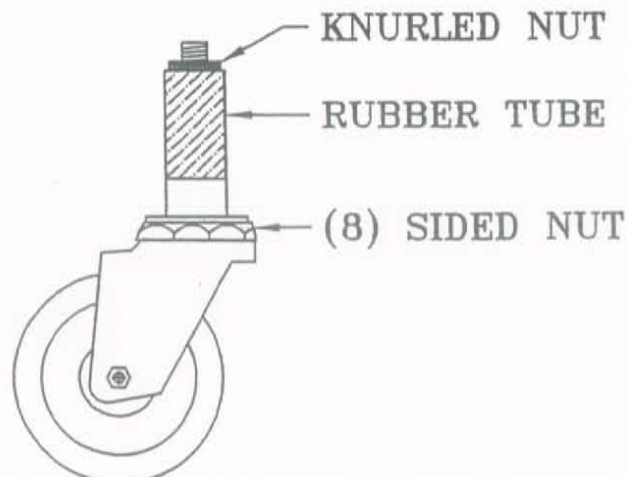

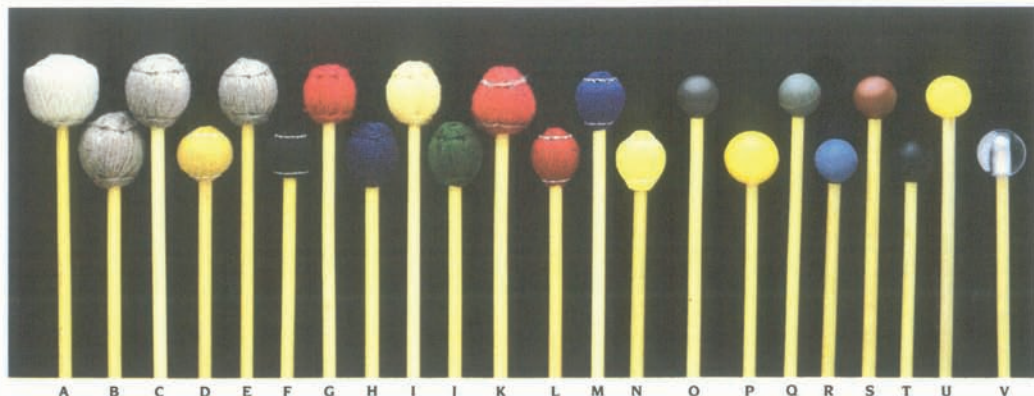

Rattan Handle Mallets

These high quality mallets feature select rattan handles. Rubber heads are hardness-graduated for a wide selection of tonal responses. Finest grade cord or yarn is used on covered mallets. Each mallet is carefully matched and balanced for flex, weight, and size. Packed in clear-view vinyl cases. The professional Gary Burton Signature Mallets (M-220, M-221) are crafted to his personal specifications.

| Description | Model No. | Description | Model No. |
|--|-----------|---|-----------|
| A. Yarn 1 1/8", Very Soft, Natural (M) | M-204 | N. Cord 1", Soft, Yellow (V) | M-218 |
| B. Yarn 1 1/8", Very Soft, Gray (M) | M-223 | O. Phenolic 1", Hard, Brown (B, X) | M-215 |
| C. Yarn 1 1/8", Soft, Gray (M) | M-210 | P. Rubber 1 1/8", Medium Soft, Yellow (M) | M-205 |
| D. Yarn 1 1/8", Medium Hard, Gold (M, V) | M-221 | Q. Rubber 1", Hard, Gray (B, X) | M-214 |
| E. Yarn 1 1/8", Soft, Gray (M) | M-209 | R. Rubber 1", Medium Hard, Blue (M, B, X) | M-213 |
| F. Yarn 1 1/8", Soft, Black (M, V) | M-220 | S. Rubber 1", Medium, Red (M, X) | M-212 |
| G. Yarn 1", Hard, Red (M) | M-206 | T. Rubber 1", Medium Soft, Black (M) | M-224 |
| H. Yarn 1", Medium, Blue (M, V) | M-207 | U. Rubber 1", Soft, Yellow (M) | M-211 |
| I. Yarn 1", Medium Soft, Yellow (M) | M-208 | V. Lexan 1 1/8", Very Hard, Clear (B, X) | M-203 |
| J. Yarn 1", Soft, Green (M) | M-222 | | |
| K. Yarn 1", Soft, Red (M) | M-219 | | |
| L. Cord 1", Hard, Red (V, X) | M-216 | | |
| M. Cord 1", Medium, Blue (V) | M-217 | | |

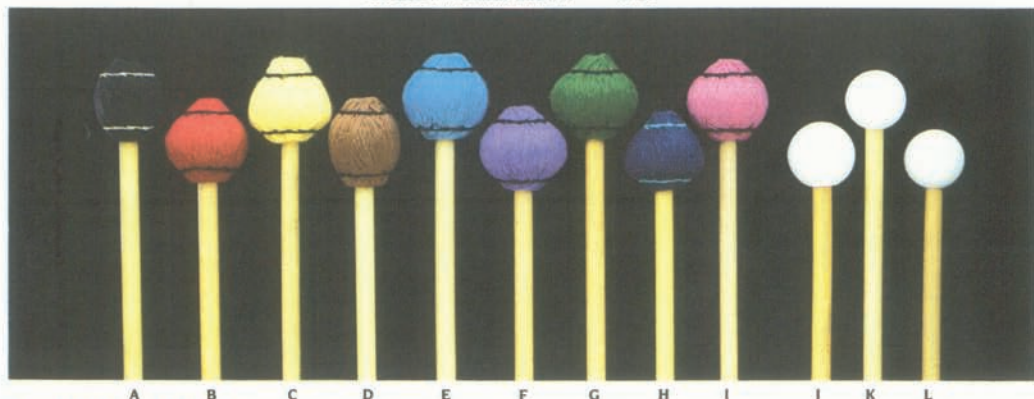

Good Vibes Mallets

Good Vibes are recognized as the world's finest professional mallets. Handles are choice light rattan, carefully selected and matched for size, weight, and flex. Select premium yarn is wound around a solid, specially formulated and shaped rubber core, then carefully hand-stitched. Packed in clear-view vinyl cases.

| Description | Model No. | Description | Model No. |
|---|-----------|---|-----------|
| A. Yarn 1 1/8", Hard, Black (X) | M-232 | G. Yarn 1 1/8", Medium Hard, Green (V) | M-239 |
| B. Yarn 1 1/8", Hard, Red (V) | M-236 | H. Yarn 1 1/8", Medium Soft, Navy Blue (M, V) | M-228 |
| C. Yarn 1 1/8", Medium Hard, Yellow (M, V) | M-229 | I. Yarn 1 1/8", Medium Soft, Pink (V) | M-233 |
| D. Yarn 1 1/8", Medium Hard, Brown (X) | M-231 | J. Poly 1 1/8", Medium Hard, White (B, X) | M-226 |
| E. Yarn 1 1/8", Medium Hard, Royal Blue (V) | M-235 | K. Poly 1", Medium Hard, White (B, X) | M-225 |
| F. Yarn 1 1/8", Medium Hard, Violet (V) | M-237 | L. Nylon 1", Hard, White (B, X) | M-227 |

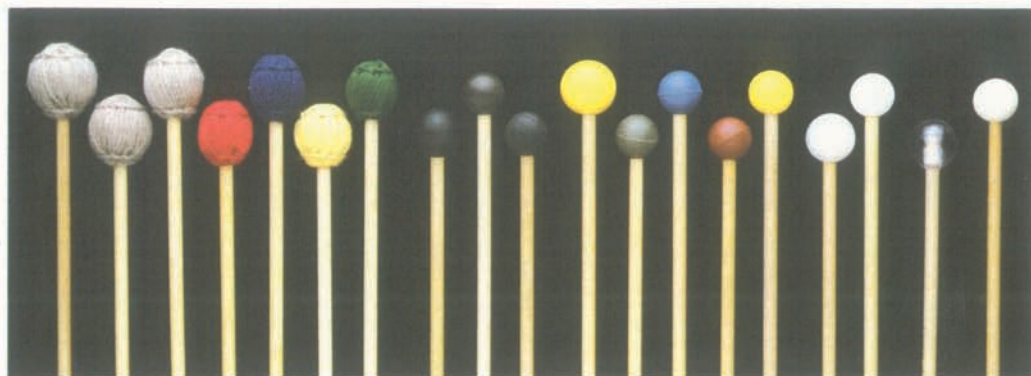

Birch Handle Mallets

For the mallet player who wants a straight, but firmer, wood handle mallet. Precision matched for balance, these mallets come with rubber, plastic, or yarn heads. Packaged in clear vinyl cases.

| Description | Model No. | | Model No. |
|--|-----------|---|-----------|
| A. Yarn 1 1/8". Very Soft, Gray (M) | M-412 | K. Rubber 1 1/8", Medium Soft, Yellow (M) | M-413 |
| B. Yarn 1 1/8", Soft, Gray (M) | M-410 | L. Rubber 1", Hard, Gray (B, X) | M-404 |
| C. Yarn 1 1/8", Soft, Gray (M) | M-409 | M. Rubber 1", Medium Hard, Blue (M, B, X) | M-403 |
| D. Yarn 1", Hard, Red (M) | M-406 | N. Rubber 1", Medium, Red (M, X) | M-402 |
| E. Yarn 1", Medium, Blue (M, V) | M-407 | O. Rubber 1", Soft, Yellow (M) | M-401 |
| F. Yarn 1", Medium Soft, Yellow (M) | M-408 | P. Poly 1 1/8", Medium Hard, White (B, X) | M-4226 |
| G. Yarn 1", Soft, Green (M) | M-411 | Q. Poly 1", Medium Hard, White (B, X) | M-4225 |
| H. Phenolic 1 1/8", Hard, Black (B, X) | M-424 | R. Lexan 1 1/8", Very Hard, Clear (B, X) | M-423 |
| I. Phenolic 1", Hard, Brown (B, X) | M-405 | S. Nylon 1", Hard, White (B, X) | M-4227 |
| J. Phenolic 1", Hard, Black (B, X) | M-428 | | |

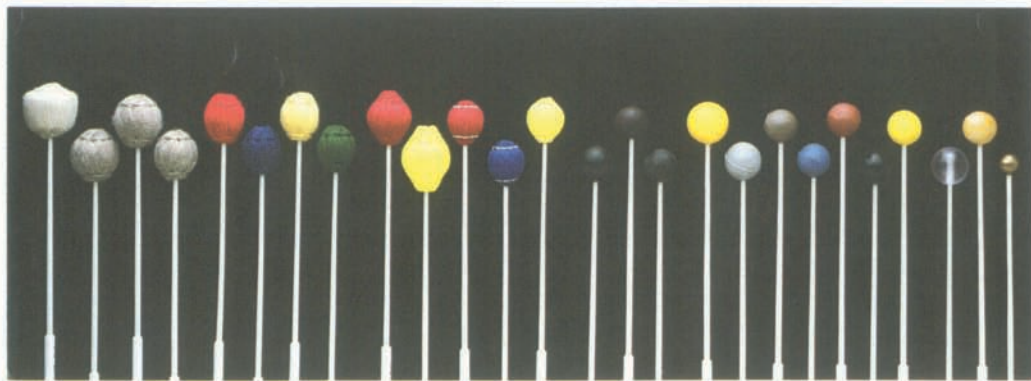

Two-Step Handle Mallets

Musser's exclusive two-step fiber-glass handles are thick near the end for well-balanced handling and thin near the head for strong striking force. Excellent flexibility, yet highly warp resistant. All mallets precision matched for balance. Available in a wide variety of graduated rubber, plastic, metal, and wood balls as well as cord or yarn-covered balls. Packaged in clear vinyl cases.

| Description | Model No. | | Model No. |
|---|-----------|--|-----------|
| A. Yarn 1 1/8". Soft, Natural (M) | M-19 | P. Phenolic 1", Hard, Black (B, X) | M-28 |
| B. Yarn 1 1/8". Very Soft, Gray (M) | M-12 | Q. Rubber 1 1/8", Medium Soft, Yellow (M) | M-13 |
| C. Yarn 1 1/8". Soft, Gray (M) | M-10 | R. Rubber 1 1/8", Hard, Gray (B, X) | M-22 |
| D. Yarn 1 1/8". Soft, Gray (M) | M-9 | S. Rubber 1", Hard, Gray (B, X) | M-4 |
| E. Yarn 1", Hard, Red (M) | M-6 | T. Rubber 1", Medium Hard, Blue (M, B, X) | M-3 |
| F. Yarn 1", Medium, Blue (M, V) | M-7 | U. Rubber 1", Medium, Red (M, X) | M-2 |
| G. Yarn 1", Medium Soft, Yellow (M) | M-8 | V. Rubber 1", Medium Soft, Black (M) | M-25 |
| H. Yarn 1", Soft, Green (M) | M-11 | W. Rubber 1", Soft, Yellow (M) | M-1 |
| I. Cord 1 1/8", Medium Hard, Red (M, V) | M-27 | X. Lexan 1 1/8", Very Hard, Clear (B, X) | M-23 |
| J. Cord 1 1/8", Medium, Yellow (M, V) | M-29 | Y. Wood 1", Hard, Maple () | M-15 |
| K. Cord 1", Hard, Red (V, X) | M-16 | Z. Brass 3/8", Very Hard, Gold (Steel Bells) | M-14 |
| L. Cord 1", Medium, Blue (V) | M-17 | | |
| M. Cord 1", Soft, Yellow (V) | M-18 | | |
| N. Phenolic 1 1/8", Hard, Black (B, X) | M-24 | | |
| O. Phenolic 1", Hard, Brown (B, X) | M-5 | | |

USAGE CODE: V = Vibraphone, M = Marimba, X = Xylophone, B = Bells

HOW TO OBTAIN MALLETS, REPLACEMENT PARTS, OR SERVICE

CONTACT YOUR LOCAL LUDWIG/MUSSER AUTHORIZED DEALER. THE DEALER WILL CONTACT OUR DEALER SERVICE DEPARTMENT TO ASSIST YOU.

IF YOU CANNOT LOCATE AN AUTHORIZED DEALER, PLEASE CALL 574-522-1675 AND ASK FOR DEALER SERVICE.

**VISIT OUR LUDWIG/MUSSER
WEB SITE ON THE INTERNET
<http://www.ludwig-drums.com>**

Products

- Drum Outfits
- Snare Drums
- Marching Percussion
- Concert Percussion
- Educational Percussion
- Hardware

Promotional Items

- Catalogs/Brochures
- Posters
- Wearable Items

What's New

- New Product Press Releases
- Percussion Events

Artists/Clinicians

- Drum Outfits
- Marching
- Mallet Instrument
- Total Percussion

Dealers

- USA by State
- Canada by Province
- International Distributors