

MUSSEER

A DIVISION OF THE SELMER COMPANY, INC.

M360 COLISEUM GRAND MARIMBA



505 SHAWMUT AVE., LA GRANGE, ILLINOIS 60525 U.S.A. 708.354.8383, FAX 708.354.8403

musser

A DIVISION OF THE CONN-SELMER, INC.

Dear Customer,

We at Musser want to thank you for selecting one of our percussion instruments. Generations of **American Craftsmanship**, Knowledge and Pride go into each and every **Musser** product.

In striving to offer the highest quality instruments and service in meeting your musical needs, we ask that you please complete both the registration Form and our Customer Satisfaction Survey.

If you are pleased, **tell everyone**; if you are not, **please let us know**.
WE WANT TO KNOW!

Specifications are subject to change without notice as we at Musser continue to improve our products. The information in this manual is intended to be of a general nature only.

Thank you,

All Employees
Musser Division
Conn-Selmer Inc.

ASSEMBLY INSTRUCTIONS FOR THE M360 COLISEUM GRAND MARIMBA

PARTS LIST

One (1) Narrow End Piece and Plate Assembly	One (1) Wide End Piece
Two (2) Crossbar Assemblies (2 sections)	Four (4) Rail Assemblies
Two (2) Diagonal Braces with Plastic Knobs	One (1) Plain Scale Keyboard
Two (2) Resonator Assemblies	Two (2) Pairs of Mallets
One (1) Sharp Scale Keyboard	One (1) Dust Cover

Note: Due to the size of your new instrument, it is advisable to have someone assist you in assembly.

Step 1 Remove contents from the cartons and check against Parts List.

Step 2 Assemble the two sections of each Crossbar. Pull Pin "C" toward you and slide Insert "A" into Sleeve "B". Release pin into hole through both sections of Crossbar.

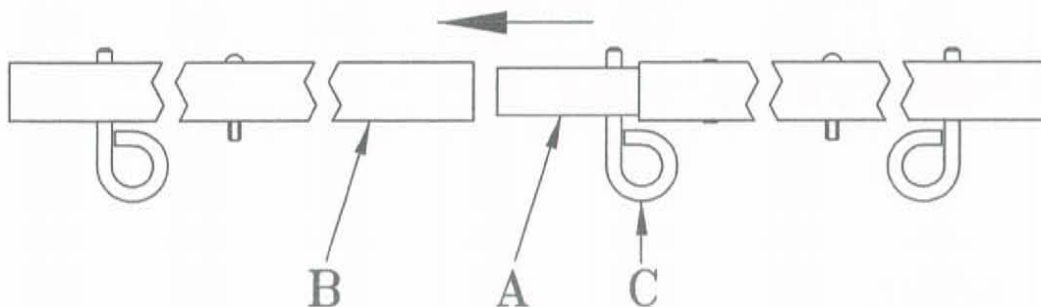

Step 3 Place the Large Metal End Piece (Decal side down) on a flat, smooth surface. Retract the Spring Loaded Pin at one end of each Crossbar. Slide the end of each Crossbar into the Sleeve attached to the end piece. Align the Crossbar Pin with the hole in the Sleeve. Release the Pin, making certain the Pin is fully through the hole in the Sleeve. Place this End Piece upright on it's Casters.

Step 4

Retract the Spring Loaded Pin at the free end of each Crossbar. Guide the end of each Crossbar into the proper Sleeve on the Narrow End Piece. Align the Pin with the Hole in the Sleeve and release it fully through the Sleeve Hole.

Step 5

Assemble the Diagonal Braces to the Crossbar and End Pieces as shown below. Make certain the Plastic Knobs are securely tightened.

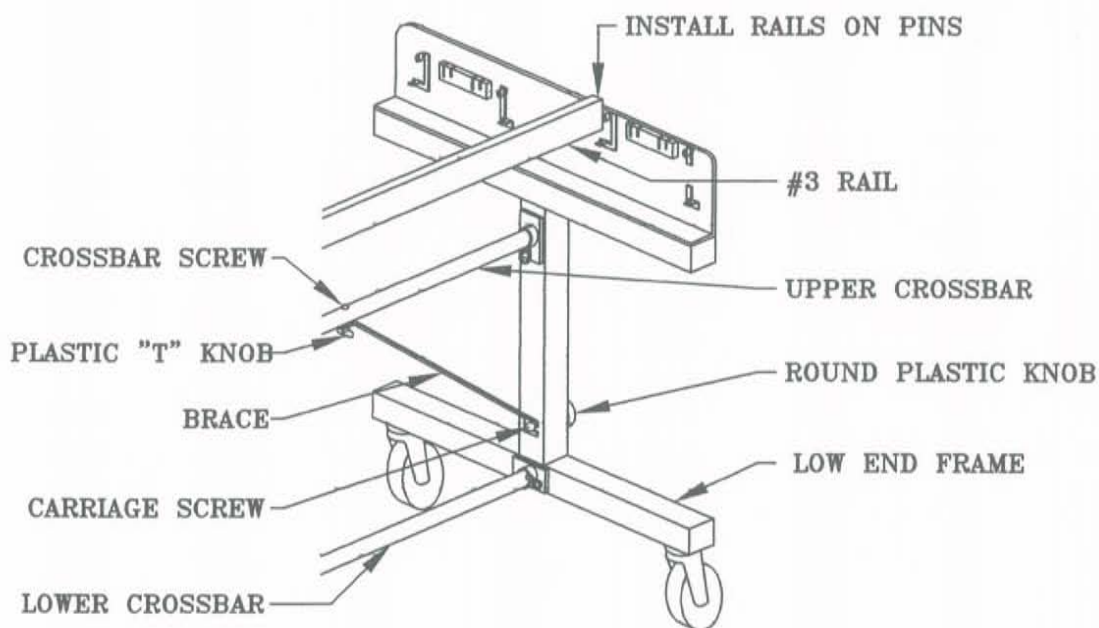

Step 6

Open the Hinged Wooden Rail Assemblies completely. Note the Stamped Number on one end. The Number One Rail is positioned closest to the Player. Loosen the Two Plastic Knobs on the Narrow End Piece, just enough to allow the Top Plate to slide back and forth. Install the Rails on the End Pins attached to each End Piece, starting with the Two Middle Rails #2 & #3. Make certain the Rails are pushed down completely onto the Pins. Connect Rails #2 & #3 together by swinging the Round Wire on the Bottom of the #2 Rail toward the Hole in the Wood Block on the #3 Rail.

- Step 7** Open the Natural Scale Resonator Section completely. Hook the Resonator Latch "D" in place. Place the Resonator into the Rubber Blocks on the Wide End and Narrow End of the instrument. Do the same with the Sharp Scale Resonator.

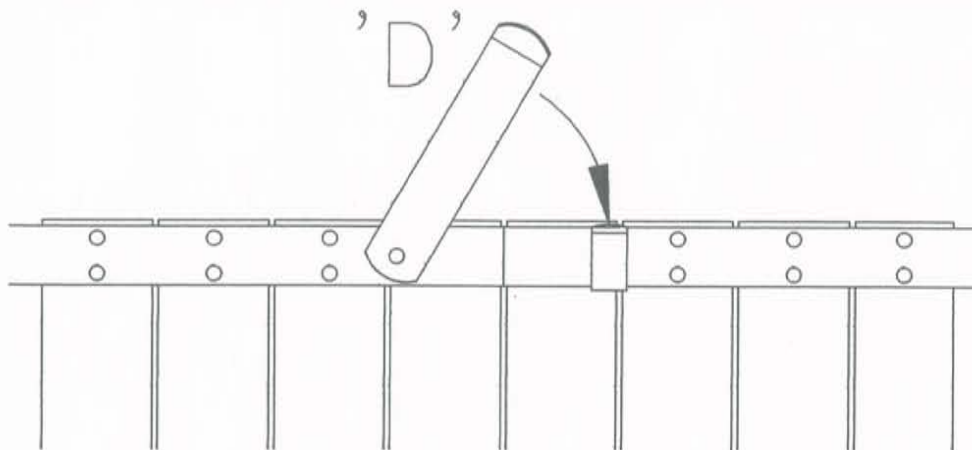

- Step 8** Open #1 Rail completely and install onto the End Piece Pins. Do the same with the #4 Rail. Lift the #1 Rail slightly, in the middle, and swing the Round Wire toward the #2 Rail. The Rubber Bumper on the Wire should fit between the Resonator Tube and outside strip closest to the player. Do the same with the #4 Rail. This should keep the Resonators from any excessive movement. Tighten the Plastic Knobs on the bottom of the Narrow End Piece.
- Step 9** Install the Keyboard Bars onto the Instrument.

Your new instrument is guaranteed against any defects in workmanship and material through normal use. Please use good judgement in selecting your mallets. Use of brass or steel ball mallets will nullify the guarantee. Do not use acrylic or lexan mallets on wood keyboards.

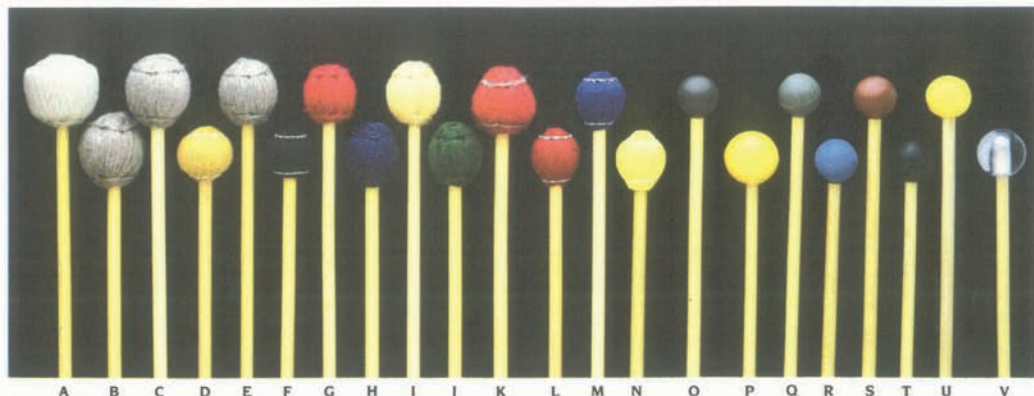

Rattan Handle Mallets

These high quality mallets feature select rattan handles. Rubber heads are hardness-graduated for a wide selection of tonal responses. Finest grade cord or yarn is used on covered mallets. Each mallet is carefully matched and balanced for flex, weight, and size. Packed in clear-view vinyl cases. The professional Gary Burton Signature Mallets (M-220, M-221) are crafted to his personal specifications.

Description	Model No.	Description	Model No.
A. Yarn 1 1/8", Very Soft, Natural (M)	M-204	N. Cord 1", Soft, Yellow (V)	M-218
B. Yarn 1 1/8", Very Soft, Gray (M)	M-223	O. Phenolic 1", Hard, Brown (B, X)	M-215
C. Yarn 1 1/8", Soft, Gray (M)	M-210	P. Rubber 1 1/8", Medium Soft, Yellow (M)	M-205
D. Yarn 1 1/8", Medium Hard, Gold (M, V)	M-221	Q. Rubber 1", Hard, Gray (B, X)	M-214
E. Yarn 1 1/8", Soft, Gray (M)	M-209	R. Rubber 1", Medium Hard, Blue (M, B, X)	M-213
F. Yarn 1 1/8", Soft, Black (M, V)	M-220	S. Rubber 1", Medium, Red (M, X)	M-212
G. Yarn 1", Hard, Red (M)	M-206	T. Rubber 1", Medium Soft, Black (M)	M-224
H. Yarn 1", Medium, Blue (M, V)	M-207	U. Rubber 1", Soft, Yellow (M)	M-211
I. Yarn 1", Medium Soft, Yellow (M)	M-208	V. Lexan 1 1/8", Very Hard, Clear (B, X)	M-203
J. Yarn 1", Soft, Green (M)	M-222		
K. Yarn 1", Soft, Red (M)	M-219		
L. Cord 1", Hard, Red (V, X)	M-216		
M. Cord 1", Medium, Blue (V)	M-217		

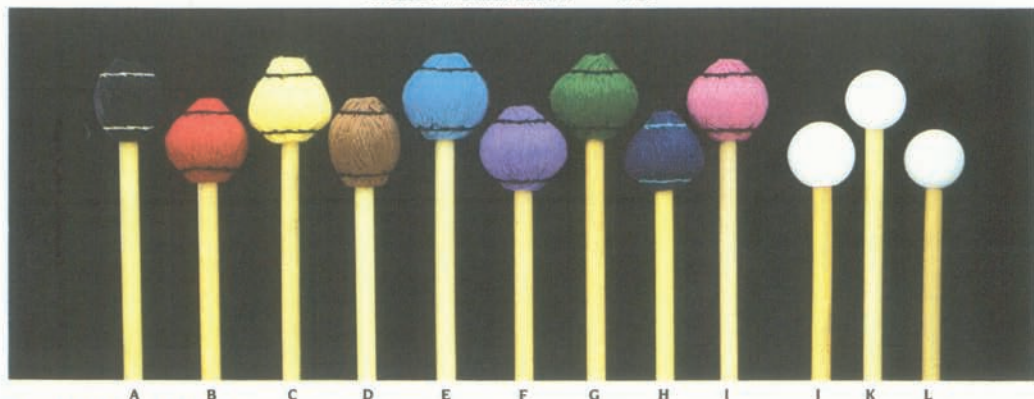

Good Vibes Mallets

Good Vibes are recognized as the world's finest professional mallets. Handles are choice light rattan, carefully selected and matched for size, weight, and flex. Select premium yarn is wound around a solid, specially formulated and shaped rubber core, then carefully hand-stitched. Packed in clear-view vinyl cases.

Description	Model No.	Description	Model No.
A. Yarn 1 1/8", Hard, Black (X)	M-232	G. Yarn 1 1/8", Medium Hard, Green (V)	M-239
B. Yarn 1 1/8", Hard, Red (V)	M-236	H. Yarn 1 1/8", Medium Soft, Navy Blue (M, V)	M-228
C. Yarn 1 1/8", Medium Hard, Yellow (M, V)	M-229	I. Yarn 1 1/8", Medium Soft, Pink (V)	M-233
D. Yarn 1 1/8", Medium Hard, Brown (X)	M-231	J. Poly 1 1/8", Medium Hard, White (B, X)	M-226
E. Yarn 1 1/8", Medium Hard, Royal Blue (V)	M-235	K. Poly 1", Medium Hard, White (B, X)	M-225
F. Yarn 1 1/8", Medium Hard, Violet (V)	M-237	L. Nylon 1", Hard, White (B, X)	M-227

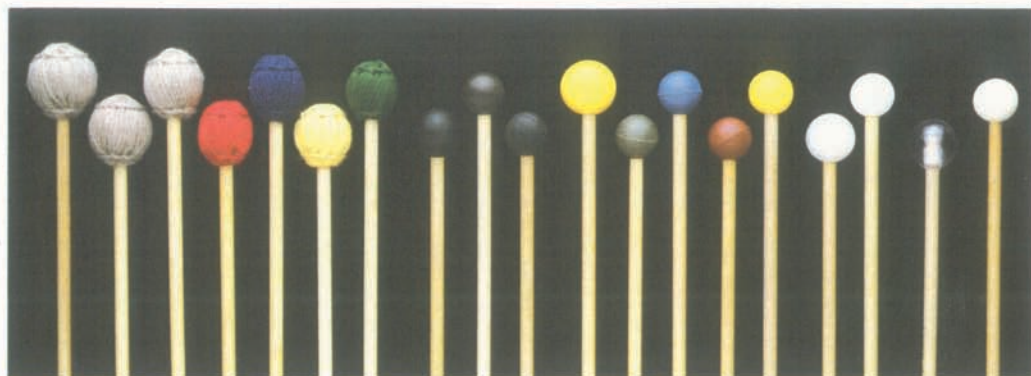

A B C D E F G H I J K L M N O P Q R S

Birch Handle Mallets

For the mallet player who wants a straight, but firmer, wood handle mallet. Precision matched for balance, these mallets come with rubber, plastic, or yarn heads. Packaged in clear vinyl cases.

Description	Model No.		
A. Yarn 1 1/8". Very Soft, Gray (M)	M-412	K. Rubber 1 1/2", Medium Soft, Yellow (M)	M-413
B. Yarn 1 1/2", Soft, Gray (M)	M-410	L. Rubber 1", Hard, Gray (B, X)	M-404
C. Yarn 1 1/8", Soft, Gray (M)	M-409	M. Rubber 1", Medium Hard, Blue (M, B, X)	M-403
D. Yarn 1", Hard, Red (M)	M-406	N. Rubber 1", Medium, Red (M, X)	M-402
E. Yarn 1", Medium, Blue (M, V)	M-407	O. Rubber 1", Soft, Yellow (M)	M-401
F. Yarn 1", Medium Soft, Yellow (M)	M-408	P. Poly 1 1/8", Medium Hard, White (B, X)	M-4226
G. Yarn 1", Soft, Green (M)	M-411	Q. Poly 1", Medium Hard, White (B, X)	M-4225
H. Phenolic 1 1/8", Hard, Black (B, X)	M-424	R. Lexan 1 1/8", Very Hard, Clear (B, X)	M-423
I. Phenolic 1", Hard, Brown (B, X)	M-405	S. Nylon 1", Hard, White (B, X)	M-4227
J. Phenolic 1", Hard, Black (B, X)	M-428		

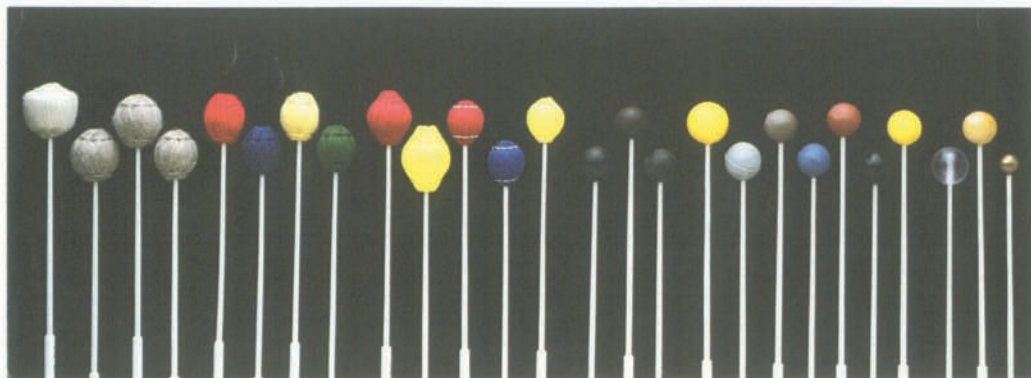

A B C D E F G H I J K L M N O P Q R S T U V W X Y Z

Two-Step Handle Mallets

Musser's exclusive two-step fiber-glass handles are thick near the end for well-balanced handling and thin near the head for strong striking force. Excellent flexibility, yet highly warp resistant. All mallets precision matched for balance. Available in a wide variety of graduated rubber, plastic, metal, and wood balls as well as cord or yarn-covered balls. Packaged in clear vinyl cases.

Description	Model No.		
A. Yarn 1 3/8", Soft, Natural (M)	M-19	P. Phenolic 1", Hard, Black (B, X)	M-28
B. Yarn 1 3/8", Very Soft, Gray (M)	M-12	Q. Rubber 1 1/2", Medium Soft, Yellow (M)	M-13
C. Yarn 1 1/2", Soft, Gray (M)	M-10	R. Rubber 1 1/8", Hard, Gray (B, X)	M-22
D. Yarn 1 1/8", Soft, Gray (M)	M-9	S. Rubber 1", Hard, Gray (B, X)	M-4
E. Yarn 1", Hard, Red (M)	M-6	T. Rubber 1", Medium Hard, Blue (M, B, X)	M-3
F. Yarn 1", Medium, Blue (M, V)	M-7	U. Rubber 1", Medium, Red (M, X)	M-2
G. Yarn 1", Medium Soft, Yellow (M)	M-8	V. Rubber 1", Medium Soft, Black (M)	M-25
H. Yarn 1", Soft, Green (M)	M-11	W. Rubber 1", Soft, Yellow (M)	M-1
I. Cord 1 1/2", Medium Hard, Red (M, V)	M-27	X. Lexan 1 1/8", Very Hard, Clear (B, X)	M-23
J. Cord 1 1/2", Medium, Yellow (M, V)	M-29	Y. Wood 1", Hard, Maple ()	M-15
K. Cord 1", Hard, Red (V, X)	M-16	Z. Brass 3/8", Very Hard, Gold (Steel Bells)	M-14
L. Cord 1", Medium, Blue (V)	M-17		
M. Cord 1", Soft, Yellow (V)	M-18		
N. Phenolic 1 1/8", Hard, Black (B, X)	M-24		
O. Phenolic 1", Hard, Brown (B, X)	M-5		

USAGE CODE: V = Vibraphone, M = Marimba, X = Xylophone, B = Bells

HOW TO OBTAIN MALLETS, REPLACEMENT PARTS, OR SERVICE

CONTACT YOUR LOCAL LUDWIG/MUSSER AUTHORIZED DEALER. THE DEALER WILL CONTACT OUR DEALER SERVICE DEPARTMENT TO ASSIST YOU.

IF YOU CANNOT LOCATE AN AUTHORIZED DEALER, PLEASE CALL 574-522-1675 AND ASK FOR DEALER SERVICE.

**VISIT OUR LUDWIG/MUSSER
WEB SITE ON THE INTERNET
<http://www.ludwig-drums.com>**

Products

- Drum Outfits
- Snare Drums
- Marching Percussion
- Concert Percussion
- Educational Percussion
- Hardware

Artists/Clinicians

- Drum Outfits
- Marching
- Mallet Instrument
- Total Percussion

Promotional Items

- Catalogs/Brochures
- Posters
- Wearable Items

What's New

- New Product Press Releases
- Percussion Events

Dealers

- USA by State
- Canada by Province
- International Distributors