

musser

A DIVISION OF THE CONN-SELMER INC.

MUSSER M245 MARIMBA



STUDIO SOLOIST

505 SHAWMUT AVE., LA GRANGE ILLINOIS 60525 U.S.A.

CUSTOMER SERVICE 1-574-522-1675

musser

A DIVISION OF THE CONN-SELMER, INC.

Dear Customer,

We at Musser want to thank you for selecting one of our percussion instruments. Generations of **American Craftsmanship**, Knowledge and Pride go into each and every **Musser** product.

In striving to offer the highest quality instruments and service in meeting your musical needs, we ask that you please complete both the registration Form and our Customer Satisfaction Survey.

If you are pleased, **tell everyone**; if you are not, **please let us know**.
WE WANT TO KNOW!

Specifications are subject to change without notice as we at Musser continue to improve our products. The information in this manual is intended to be of a general nature only.

Thank you,

All Employees
Musser Division
Conn-Selmer Inc.



SPECIFICATIONS FOR MUSSER STUDIO SOLOIST MARIMBA

MODEL NUMBER: M245 **NAME:** STUDIO SOLOIST

KEYBOARD SPECIFICATIONS: **RANGE:** 4.3 Octaves - 52 Notes - A2 TO C7

BAR SIZES: Length of lowest note 17-7/8" graduating down to 7-5/8" highest note.

WIDTH AND THICKNESS: A2 to F 2-1/2" wide by 15/16" thick
F3# to C 2-1/4" wide by 15/16" thick

PITCH: Bars tuned to A-442 Pitch C4# to C5 2" wide by 15/16" thick
C5# to C6 1-3/4" wide by 7/8" thick

MATERIAL: High grade Rosewood C6# to C7 1-5/8" wide by 3/4" thick

FINISH: Painted with clear lacquer and hand rubbed.

RESONATOR SPECIFICATIONS:

MATERIAL: High grade light aluminum alloy tubing.

FINISH: Durable scratch resistant silver vein powder coating.

CONSTRUCTION: Braces shall be 1/8" thick steel fastened with screws and locking nuts to aluminum resonators. Resonators are hinged to fold in half and are solidly braced to eliminate any sag.

FRAMEWORK: The end supports and rails are made of selected hardwood and painted to a black Plextone finish. Size: High end 17" wide, Low end 32" wide x 37.5" tall x 82" long. Total weight is 145lbs.

ASSEMBLY INSTRUCTIONS FOR M245 STUDIO SOLOIST MARIMBA

PARTS LIST

| | |
|--|------------------------------|
| One (1) Wide End Piece | One (1) Narrow End Piece |
| Two (2) Crossbar Assemblies (2 sections) | Four (4) Rail Assemblies |
| Three (3) sets of Knobs for Crossbar | One (1) Plain Scale Keyboard |
| Two (2) Diagonal Braces with Plastic Knobs | One (1) Pair of Mallets |
| Two (2) Resonator Assemblies | One (1) Dust Cover |
| One (1) Sharp Scale Keyboard | |

Note: Due to the size of your new instrument, it is advisable to have someone assist you in assembly.

- Step 1** Remove contents from the cartons and check against Parts List.
- Step 2** To assemble the two sections of the Crossbar, slide Insert "A" into Sleeve "B". Insert Hand Knob "C" into hole through both sections of Crossbar. Install and tighten Lower Hand Knob. (See illustration 1)

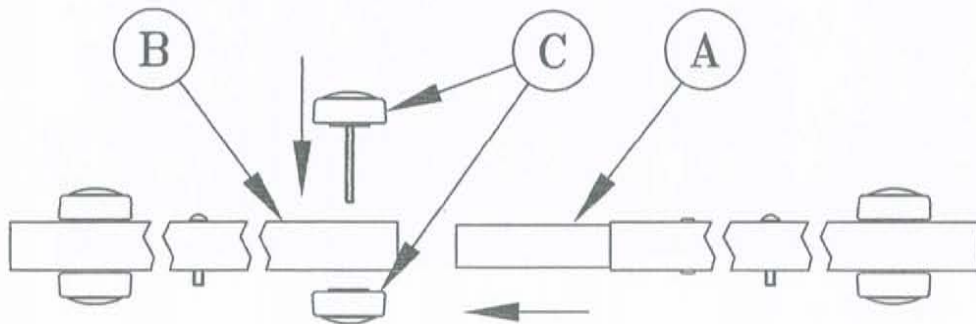

ILLUSTRATION 1

- Step 3** Place the Large End Piece on a flat, smooth surface. Slide the end of the Crossbar into the Sleeve attached to the end piece. Align the Crossbar hole with the hole in the Sleeve. Insert Hand Knob, making certain the Pin is fully through the hole in the Sleeve. Install and tighten Lower Hand Knob. Place this End Piece upright on its Casters. Install Crossbar to Small End Piece and tighten.

Step 4 Assemble the Diagonal Braces to the Crossbar and End Pieces as shown below. Make certain the Plastic Knobs are securely tightened. (See illustration 2)

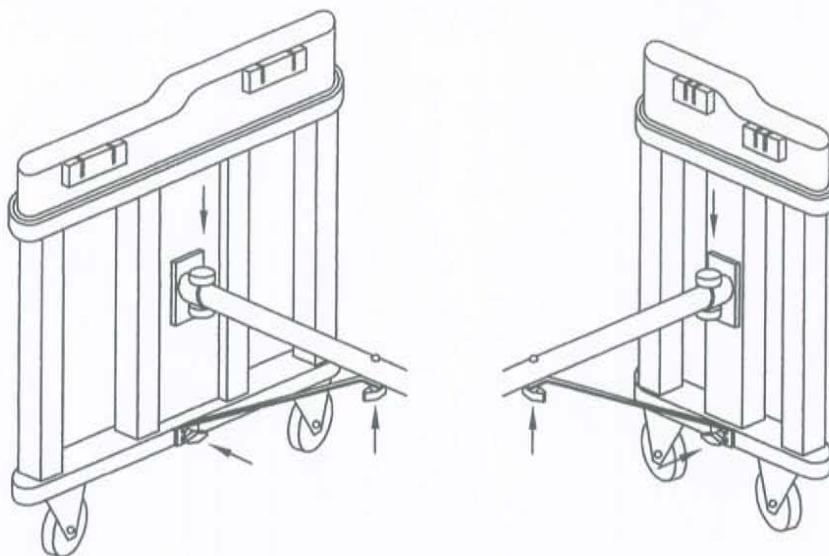

ILLUSTRATION 2

Step 5 Open the Hinged Wooden Rail Assemblies completely. Note the Stamped Number on one end. The Number One Rail is positioned closest to the Player. Install the Rails on the End Pins attached to each End Piece, starting with the Two Middle Rails #2 & #3 (See illustration 3). Make sure the Rails are pushed down completely onto the Pins. (See illustration 4)

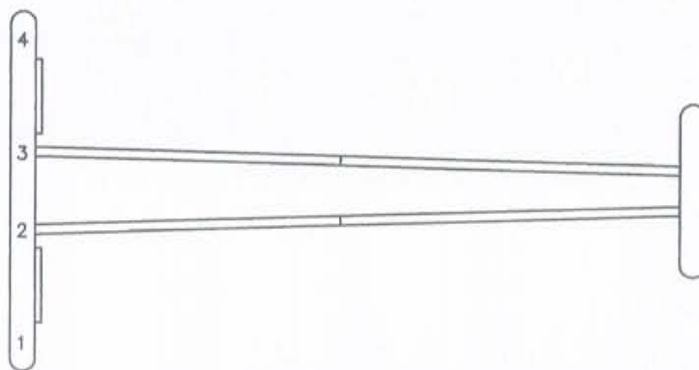

ILLUSTRATION 3

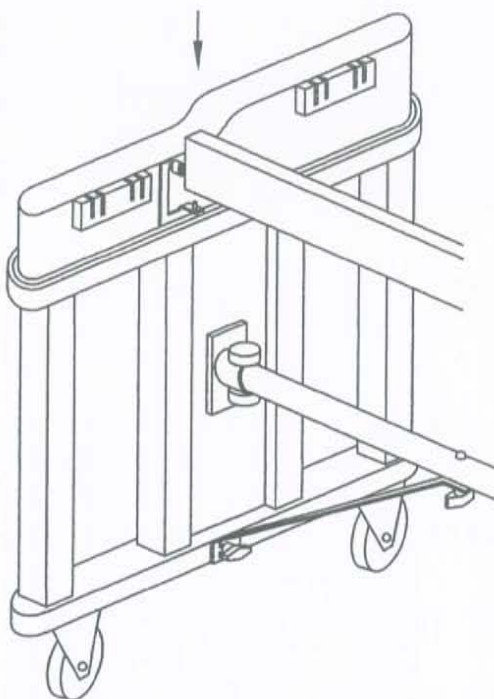

ILLUSTRATION 4

Step 6 Open the Natural Scale Resonator Section completely. Hook the Resonator Latch "D" in place (See illustration 5). Place the Resonator into the Rubber Blocks on the Wide End and Narrow End of the instrument. Do the same with the Sharp Scale Resonator.

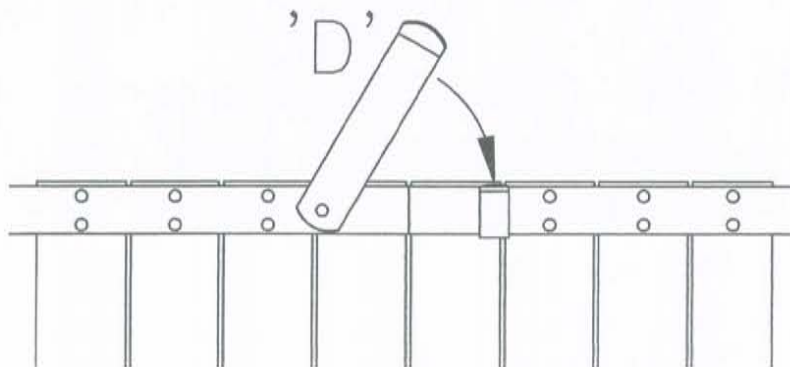

ILLUSTRATION 5

Step 7 Open #1 Rail completely and install onto the End Piece Pins. Do the same with the #4 Rail. Lift the #1 Rail slightly, in the middle, and swing the Round Wire toward the #2 Rail. The Rubber Bumper on the Wire should fit between the Resonator Tube and the outside strip closest to the player. (See illustration 6) Do the same with the #4 Rail. This should keep the Resonators from any excessive movement.

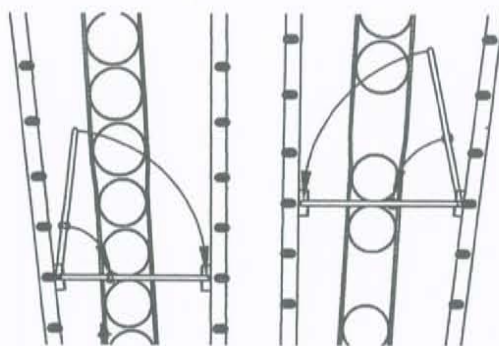

ILLUSTRATION 6

Step 8 Install the Keyboard Bars, Plain Scale first, onto the Instrument. (See illustration 7)

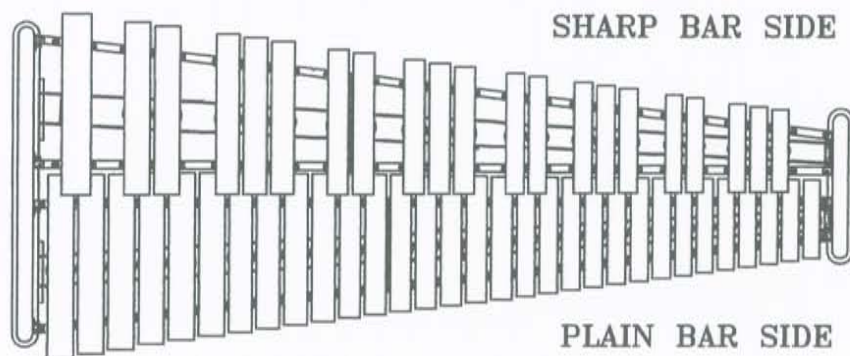
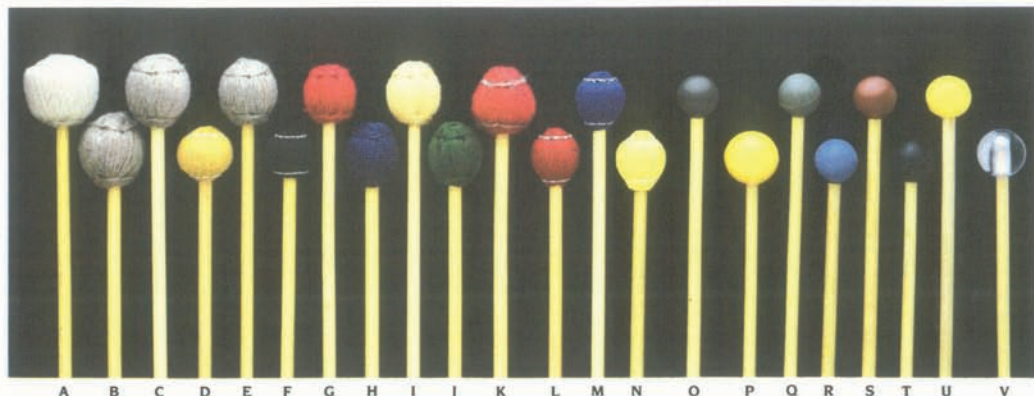

ILLUSTRATION 7

Your new instrument is guaranteed against any defects in workmanship and material through normal use. Please use good judgement in selecting your mallets. Use of brass or steel ball mallets will nullify the guarantee.

Do not use Acrylic or Lexan mallets on wood keyboards.



Rattan Handle Mallets

These high quality mallets feature select rattan handles. Rubber heads are hardness-graduated for a wide selection of tonal responses. Finest grade cord or yarn is used on covered mallets. Each mallet is carefully matched and balanced for flex, weight, and size. Packed in clear-view vinyl cases. The professional Gary Burton Signature Mallets (M-220, M-221) are crafted to his personal specifications.

| Description | Model No. | Description | Model No. |
|--|-----------|---|-----------|
| A. Yarn 1 1/8", Very Soft, Natural (M) | M-204 | N. Cord 1", Soft, Yellow (V) | M-218 |
| B. Yarn 1 1/8", Very Soft, Gray (M) | M-223 | O. Phenolic 1", Hard, Brown (B, X) | M-215 |
| C. Yarn 1 1/8", Soft, Gray (M) | M-210 | P. Rubber 1 1/8", Medium Soft, Yellow (M) | M-205 |
| D. Yarn 1 1/8", Medium Hard, Gold (M, V) | M-221 | Q. Rubber 1", Hard, Gray (B, X) | M-214 |
| E. Yarn 1 1/8", Soft, Gray (M) | M-209 | R. Rubber 1", Medium Hard, Blue (M, B, X) | M-213 |
| F. Yarn 1 1/8", Soft, Black (M, V) | M-220 | S. Rubber 1", Medium, Red (M, X) | M-212 |
| G. Yarn 1", Hard, Red (M) | M-206 | T. Rubber 1", Medium Soft, Black (M) | M-224 |
| H. Yarn 1", Medium, Blue (M, V) | M-207 | U. Rubber 1", Soft, Yellow (M) | M-211 |
| I. Yarn 1", Medium Soft, Yellow (M) | M-208 | V. Lexan 1 1/8", Very Hard, Clear (B, X) | M-203 |
| J. Yarn 1", Soft, Green (M) | M-222 | | |
| K. Yarn 1", Soft, Red (M) | M-219 | | |
| L. Cord 1", Hard, Red (V, X) | M-216 | | |
| M. Cord 1", Medium, Blue (V) | M-217 | | |

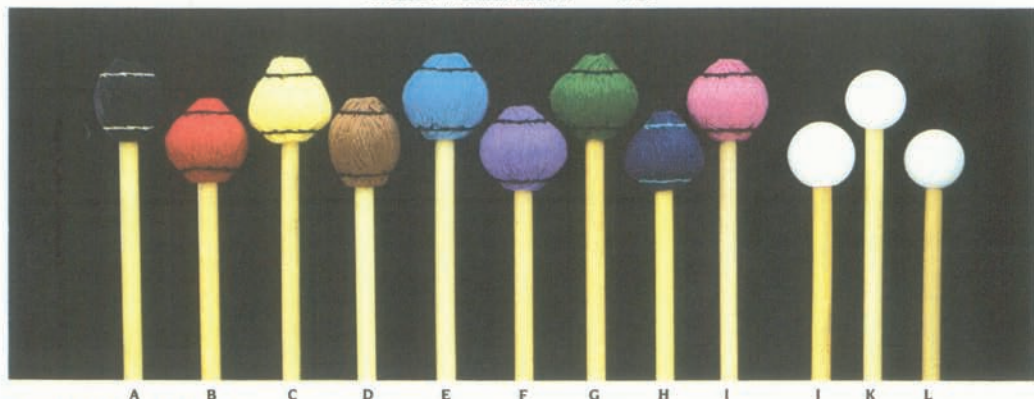

Good Vibes® Mallets

Good Vibes are recognized as the world's finest professional mallets. Handles are choice light rattan, carefully selected and matched for size, weight, and flex. Select premium yarn is wound around a solid, specially formulated and shaped rubber core, then carefully hand-stitched. Packed in clear-view vinyl cases.

| Description | Model No. | Description | Model No. |
|---|-----------|---|-----------|
| A. Yarn 1 1/8", Hard, Black (X) | M-232 | G. Yarn 1 1/8", Medium Hard, Green (V) | M-239 |
| B. Yarn 1 1/8", Hard, Red (V) | M-236 | H. Yarn 1 1/8", Medium Soft, Navy Blue (M, V) | M-228 |
| C. Yarn 1 1/8", Medium Hard, Yellow (M, V) | M-229 | I. Yarn 1 1/8", Medium Soft, Pink (V) | M-233 |
| D. Yarn 1 1/8", Medium Hard, Brown (X) | M-231 | J. Poly 1 1/8", Medium Hard, White (B, X) | M-226 |
| E. Yarn 1 1/8", Medium Hard, Royal Blue (V) | M-235 | K. Poly 1", Medium Hard, White (B, X) | M-225 |
| F. Yarn 1 1/8", Medium Hard, Violet (V) | M-237 | L. Nylon 1", Hard, White (B, X) | M-227 |

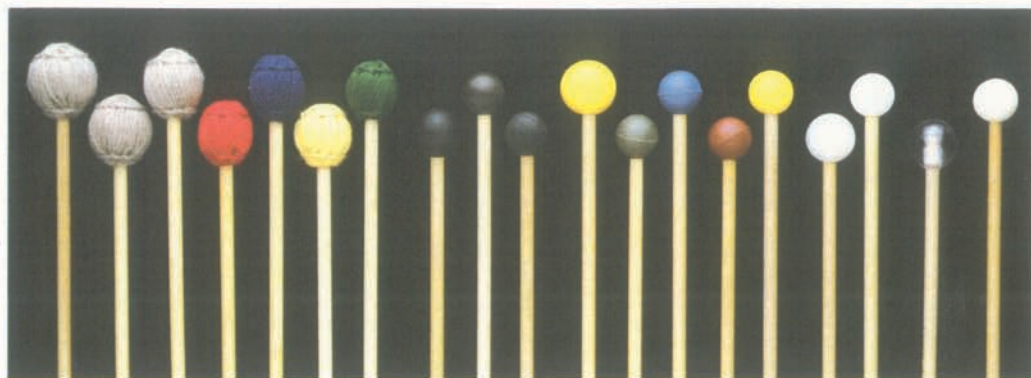

A B C D E F G H I J K L M N O P Q R S

Birch Handle Mallets

For the mallet player who wants a straight, but firmer, wood handle mallet. Precision matched for balance, these mallets come with rubber, plastic, or yarn heads. Packaged in clear vinyl cases.

| Description | Model No. | | |
|--|-----------|---|--------|
| A. Yarn 1 3/8". Very Soft, Gray (M) | M-412 | K. Rubber 1 1/2", Medium Soft, Yellow (M) | M-413 |
| B. Yarn 1 1/2", Soft, Gray (M) | M-410 | L. Rubber 1", Hard, Gray (B, X) | M-404 |
| C. Yarn 1 1/8", Soft, Gray (M) | M-409 | M. Rubber 1", Medium Hard, Blue (M, B, X) | M-403 |
| D. Yarn 1", Hard, Red (M) | M-406 | N. Rubber 1", Medium, Red (M, X) | M-402 |
| E. Yarn 1", Medium, Blue (M, V) | M-407 | O. Rubber 1", Soft, Yellow (M) | M-401 |
| F. Yarn 1", Medium Soft, Yellow (M) | M-408 | P. Poly 1 1/8", Medium Hard, White (B, X) | M-4226 |
| G. Yarn 1", Soft, Green (M) | M-411 | Q. Poly 1", Medium Hard, White (B, X) | M-4225 |
| H. Phenolic 1 1/8", Hard, Black (B, X) | M-424 | R. Lexan 1 1/8", Very Hard, Clear (B, X) | M-423 |
| I. Phenolic 1", Hard, Brown (B, X) | M-405 | S. Nylon 1", Hard, White (B, X) | M-4227 |
| J. Phenolic 1", Hard, Black (B, X) | M-428 | | |

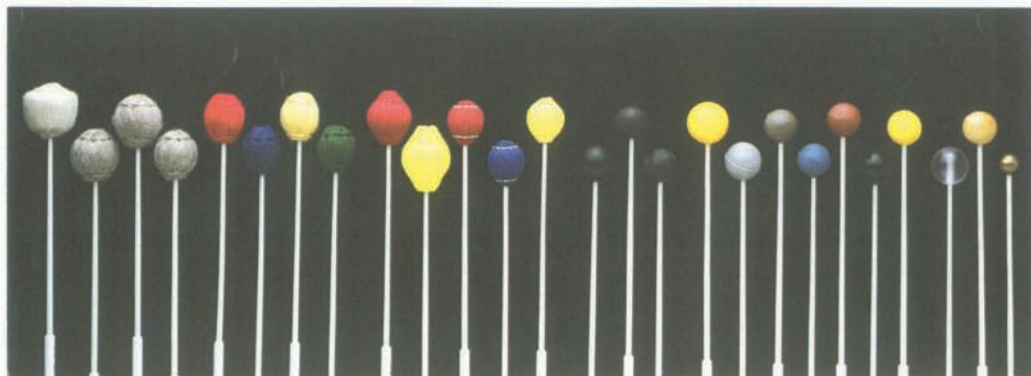

A B C D E F G H I J K L M N O P Q R S T U V W X Y Z

Two-Step Handle Mallets

Musser's exclusive two-step fiber-glass handles are thick near the end for well-balanced handling and thin near the head for strong striking force. Excellent flexibility, yet highly warp resistant. All mallets precision matched for balance. Available in a wide variety of graduated rubber, plastic, metal, and wood balls as well as cord or yarn-covered balls. Packaged in clear vinyl cases.

| Description | Model No. | | |
|---|-----------|--|------|
| A. Yarn 1 3/8". Soft, Natural (M) | M-19 | P. Phenolic 1", Hard, Black (B, X) | M-28 |
| B. Yarn 1 3/8". Very Soft, Gray (M) | M-12 | Q. Rubber 1 1/2", Medium Soft, Yellow (M) | M-13 |
| C. Yarn 1 1/2", Soft, Gray (M) | M-10 | R. Rubber 1 1/8", Hard, Gray (B, X) | M-22 |
| D. Yarn 1 1/8", Soft, Gray (M) | M-9 | S. Rubber 1", Hard, Gray (B, X) | M-4 |
| E. Yarn 1", Hard, Red (M) | M-6 | T. Rubber 1", Medium Hard, Blue (M, B, X) | M-3 |
| F. Yarn 1", Medium, Blue (M, V) | M-7 | U. Rubber 1", Medium, Red (M, X) | M-2 |
| G. Yarn 1", Medium Soft, Yellow (M) | M-8 | V. Rubber 1", Medium Soft, Black (M) | M-25 |
| H. Yarn 1", Soft, Green (M) | M-11 | W. Rubber 1", Soft, Yellow (M) | M-1 |
| I. Cord 1 1/2", Medium Hard, Red (M, V) | M-27 | X. Lexan 1 1/8", Very Hard, Clear (B, X) | M-23 |
| J. Cord 1 1/2", Medium, Yellow (M, V) | M-29 | Y. Wood 1", Hard, Maple () | M-15 |
| K. Cord 1", Hard, Red (V, X) | M-16 | Z. Brass 3/8", Very Hard, Gold (Steel Bells) | M-14 |
| L. Cord 1", Medium, Blue (V) | M-17 | | |
| M. Cord 1", Soft, Yellow (V) | M-18 | | |
| N. Phenolic 1 1/8", Hard, Black (B, X) | M-24 | | |
| O. Phenolic 1", Hard, Brown (B, X) | M-5 | | |

USAGE CODE: V = Vibraphone, M = Marimba.
X = Xylophone, B = Bells

HOW TO OBTAIN MALLETS, REPLACEMENT PARTS, OR SERVICE

CONTACT YOUR LOCAL LUDWIG/MUSSER AUTHORIZED DEALER. THE DEALER WILL CONTACT OUR DEALER SERVICE DEPARTMENT TO ASSIST YOU.

IF YOU CANNOT LOCATE AN AUTHORIZED DEALER, PLEASE CALL 574-522-1675 AND ASK FOR DEALER SERVICE.

VISIT OUR LUDWIG/MUSSER
WEB SITE ON THE INTERNET
<http://www.ludwig-drums.com>

Products

- Drum Outfits
- Snare Drums
- Marching Percussion
- Concert Percussion
- Educational Percussion
- Hardware

Artists/Clinicians

- Drum Outfits
- Marching
- Mallet Instrument
- Total Percussion

Promotional Items

- Catalogs/Brochures
- Posters
- Wearable Items

What's New

- New Product Press Releases
- Percussion Events

Dealers

- USA by State
- Canada by Province
- International Distributors