

musser

A DIVISION OF THE CONN-SELMER, INC.

M44 COMBO VIBRAPHONE



505 SHAWMUT AVE., LA GRANGE ILLINOIS 60525 U.S.A.

CUSTOMER SERVICE 1-574-522-1675

MUSSEER

A DIVISION OF THE CONN-SELMER, INC.

Dear Customer,

We at Musser want to thank you for selecting one of our percussion instruments. Generations of **American Craftsmanship**, Knowledge and Pride go into each and every **Musser** product.

In striving to offer the highest quality instruments and service in meeting your musical needs, we ask that you please complete both the registration Form and our Customer Satisfaction Survey.

If you are pleased, **tell everyone**; if you are not, **please let us know. WE WANT TO KNOW!**

Specifications are subject to change without notice as we at Musser continue to improve our products. The information in this manual is intended to be of a general nature only.

Thank you,

All Employees
Musser Division
Conn-Selmer Inc.



SPECIFICATIONS FOR MUSSER "COMBO" VIBRAPHONE

MODEL NUMBER: M44

NAME: "COMBO VIBE"

KEYBOARD SPECIFICATIONS:

RANGE: 3 Octaves - 37 Notes – F3 TO F6

BAR SIZES: Length of lowest note 12-3/8" graduating down to 7-1/8" highest note.

WIDTH AND THICKNESS:

F3 to C4	1-1/4" wide by	3/8" thick
C4# to F4	1-1/4" wide by	3/8" thick
F4# to F5	1-1/4" wide by	3/8" thick
F5# to F6	1-1/4" wide by	3/8" thick

PITCH: Bars tuned to A-442 Pitch

MATERIAL: Aluminum.

FINISH: Ball Burnished.

RESONATOR SPECIFICATIONS:

MATERIAL: High grade light aluminum alloy tubing.

FINISH: Scratch resistant silver powder coating.

CONSTRUCTION: Braces are 1/8" steel fastened with rivets to aluminum resonators.

END FRAMES: The frame is made of selected hardwood and painted to a black Plextone finish. End supports are made of aluminum tubing and fold for transport. Size: High End 15-3/8"w, Low End 27-1/4"w x 33" to 37" tall x 41-5/8"long. Total weight is 70 lbs.

MOTOR: Single speed, 115 VAC, 3-speed pulley.

MADE WITH PRIDE IN THE U.S.A

ASSEMBLY INSTRUCTIONS FOR THE M44 COMBO VIBE

(With Height Adjustable Leg Feature)

PARTS LIST

Instrument Frame

1 set of Resonators (Natural and Sharp Scale)

1 set of Bars (Natural and Sharp Scale)

Crossbar and Pedal Assembly

Read all instructions carefully before assembling the instrument.

NOTE: Do not attempt to stand the instrument on its casters without the Crossbar properly attached.

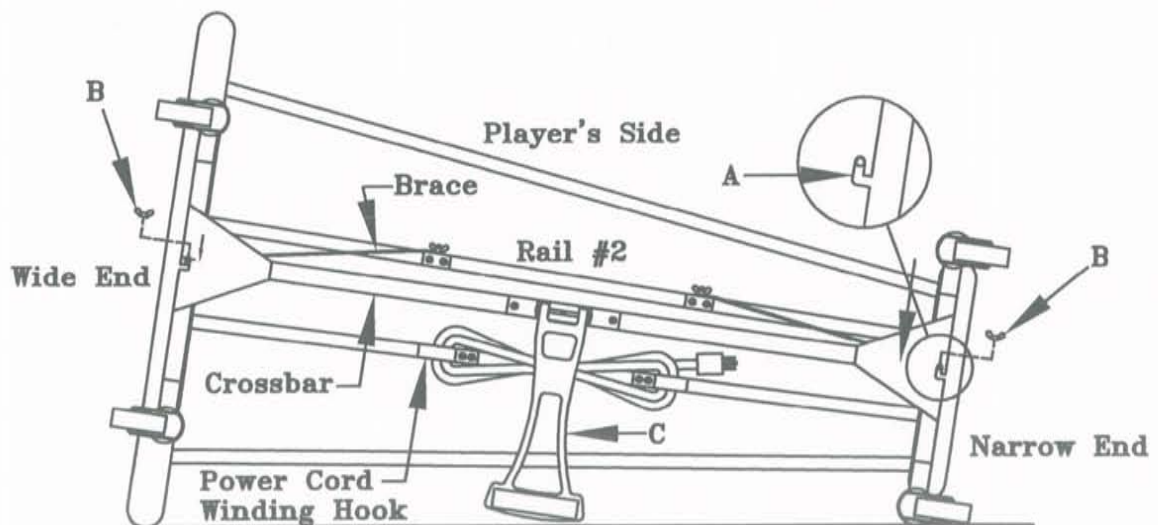

Figure 1

Bottom view of frame with legs open

1. Refer to Figure 1. Set the front of the instrument Frame on edge over a rug or several sheets of paper with the wide end of the Frame to your left.

2. **Unsnap the Legs from the Leg Lock Springs on the underside of the Frame and open the Legs completely.**
3. **Secure the Crossbar at the wide end first by sliding Slot "A" onto the Stud and under the hand knob at "B". Do the same at the narrow end. Pull the Crossbar down toward the floor so that Slot "A" is secured onto the Studs. Tighten the hand knobs securely.**

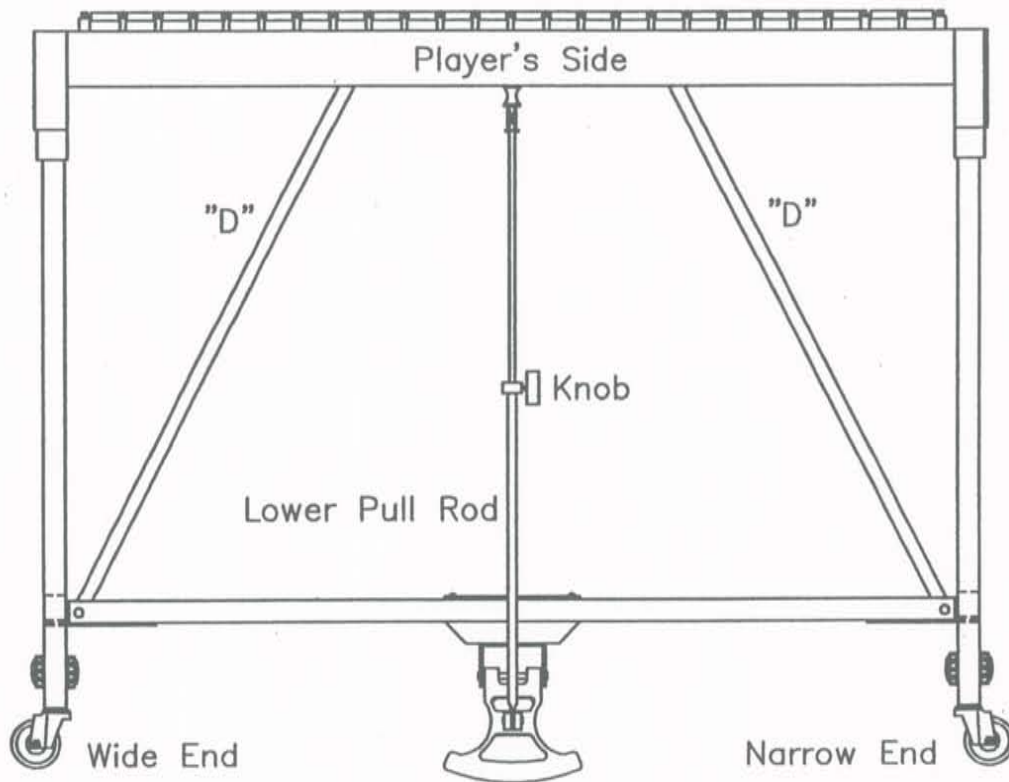

Figure 2

4. **Refer to Figure 2 and 3. With the instrument still positioned as in Figure 1, fasten diagonal braces "D" by swinging each Brace toward the Frame and attaching each one to its corresponding Stud and Wing Nut assembly on the #2 Rail (See Figure 1). Tighten the wing nuts securely. The instrument may now be set up in its normal upright position.**

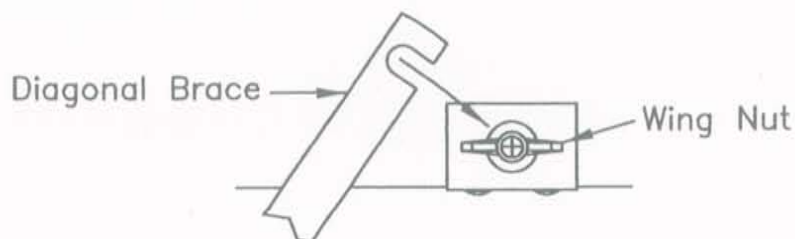

Figure 3

5. Height adjustable feature:

The height adjustment feature is simple, yet effective, and provides 4" of height adjustment. The Damper foot Pedal is also height adjustable for player comfort.

Note: If this feature is adjusted with the instrument in the upright playing position, it is necessary to have two people complete this task. One person will lift the end of the frame, holding it securely in place, while the other person adjusts and secures the Leg Insert with Caster attached.

Making sure the instrument is safely supported, unscrew the Knob with the through hole and remove the Knob with the Threaded Stud attached. Raise or lower the Frame to one of the four (4) height positions. This is determined by the selection of one of the holes in the Leg Insert with the Caster attached. Replace the Knob, with the Threaded Stud, through the hole in the Leg and tighten this together with the through hole Knob on the opposite side and tighten securely. Repeat this procedure for the other three Caster locations.

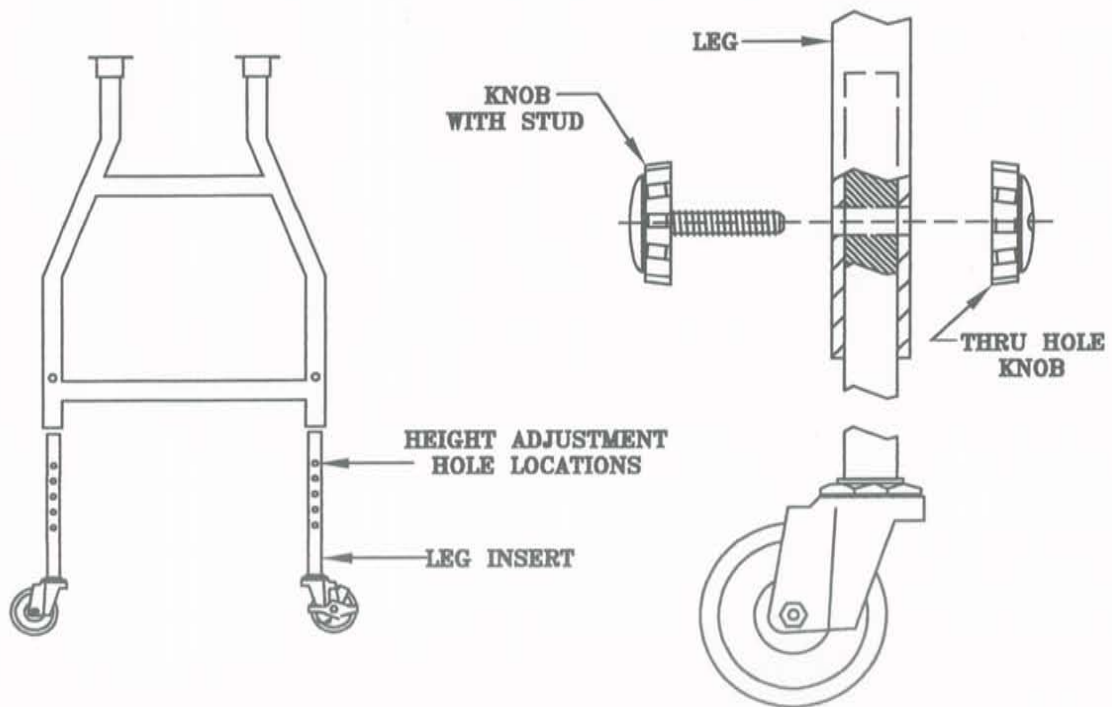

Figure 4

6. Swivel the Pedal so that it points toward the #1 Rail (Arrow C in Figure I). Refer to Figure V. To attach the Damper Pedal to the Damper Bar: (A) Loosen the hand knob on the Lower Pull Rod. (B) Pull down Spool "E". (C) Hook the Upper Pull Rod into the Eyebolt on the Damper Bar.

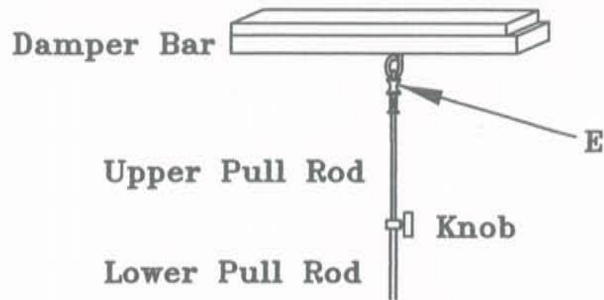

Figure 5

When Motor is used, unwind the Motor Power Cord and plug into a suitable electrical outlet. If the Motor is not being used, or when the instrument is being transported, the Power Cord should be kept wound tight around the Power Cord Winding Hooks on the underside of the Frame. It is recommended the Cord be wound in a tight Figure 8 Pattern as in Figure 1.

7. Refer to Figure 6. Place the Sharp Scale Resonator under the Frame. Slide the small end of the Resonator into the cutouts on the narrow Frame end. This end of the Resonator should rest inside the Frame End as shown in Figure 7. Bring the other end of the Resonator up toward the Frame as shown in Figure 6. Refer to Figure 8 and notice how one of the Resonator Strips passes between the two Rubber Resonator blocks and the other Strip passes between the Rubber Block and the #1 Rail. Center the Strips over the Slots in the Blocks and press them into place. Make certain, when the Resonator Strips are placed in the Slots of the Rubber Blocks, the Resonator is pulled back toward the wide end of the Frame as far as it will go as indicated by Arrow "F". Repeat the same procedure to install the Natural Scale Resonator.

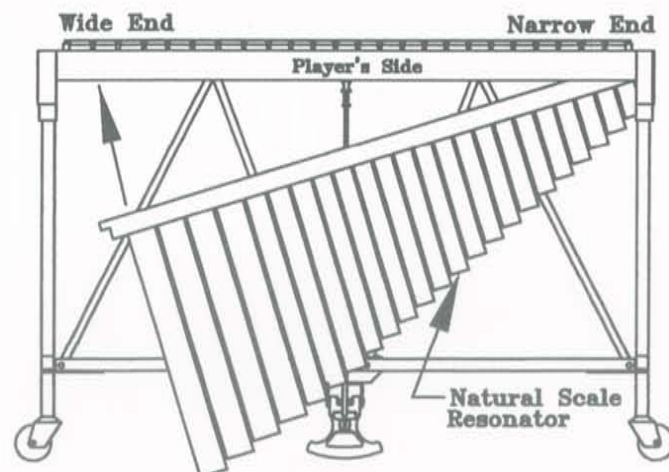

Figure 6

NARROW END OF INSTRUMENT

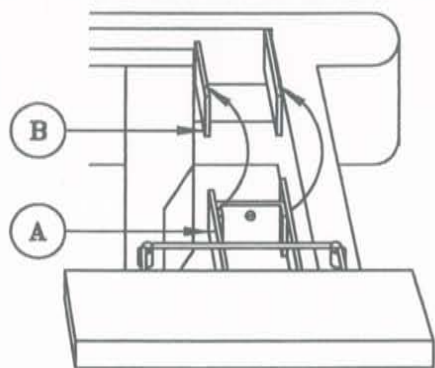

Figure 7

WIDE END OF INSTRUMENT

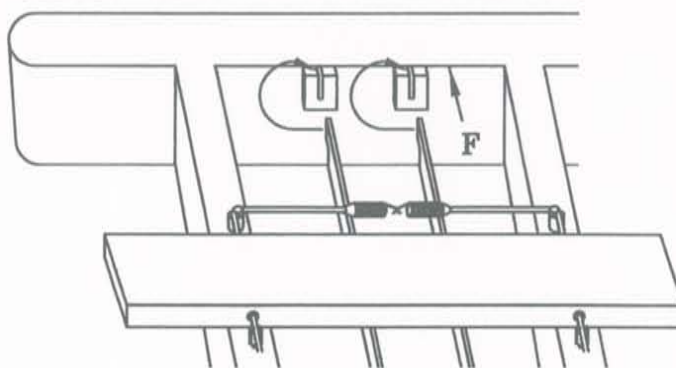

Figure 8

8. Refer to Figure 9. To install the Rubber Drive Belt (located at the narrow end of the instrument): (a) Slip the Drive Belt around the Pulley on the Motor. If your model has no motor, start with step b. (b) Slip the Belt around one of the Resonator pulleys. (c) Stretch the Belt by hand and slip it around the other Resonator pulley. Pull the belt by hand to insure it is correctly hooked onto the Resonator Pulleys. Try to align the pulsators evenly by holding onto one pulley while rotating the other.

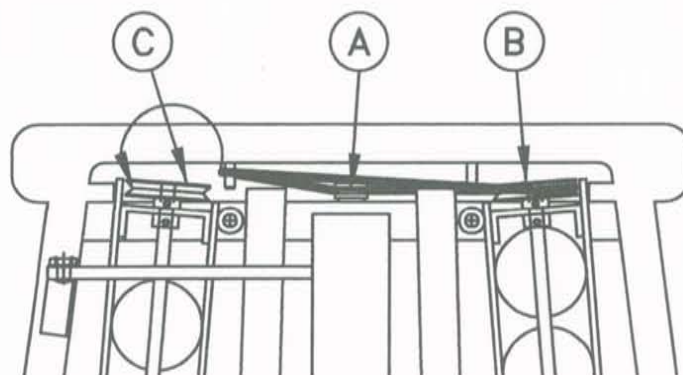

Figure 9

9. It is very important to remember, when your not using the motor, that the Pulsator Discs be set at a 45 degree angle to achieve the most balanced resonance across the entire keyboard. See Figure 10.

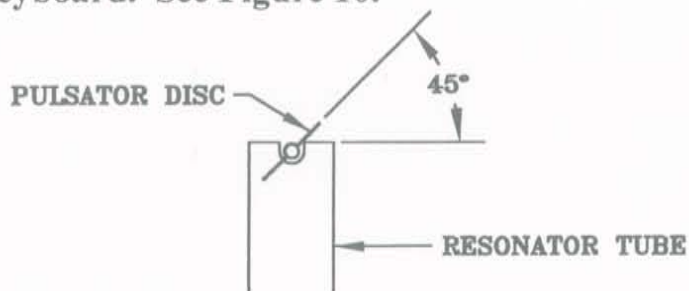

Figure 10

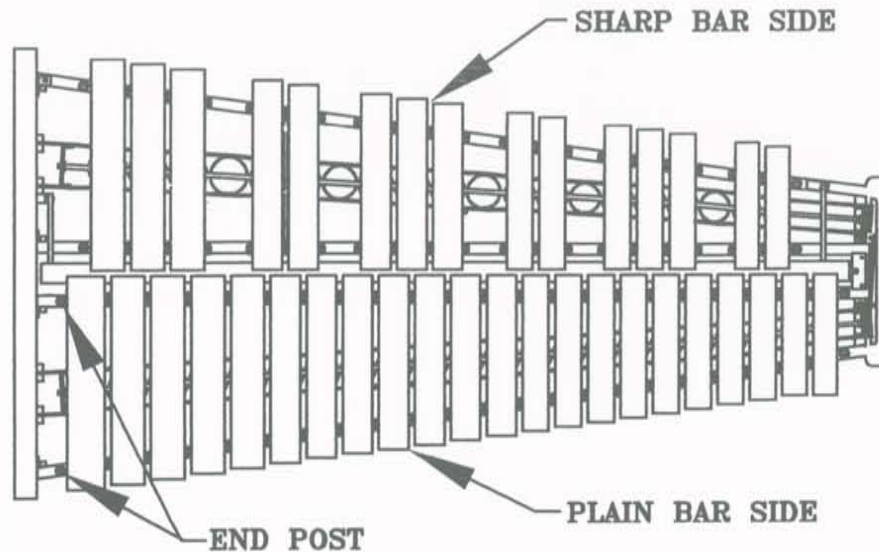

Figure 11

10. Refer to Figure 11. Place the Natural Scale Bars on the Instrument and unhook the Springs. Place the Bar Cord around the End Posts at the narrow end of the instrument (See Figure 7 for End post location). Start placing the Bars between the Bar Support Posts at the wide end of the instrument (See Figure 8) and work toward the narrow end until all the Bars are in Place. Hook the Springs together. Repeat the same procedure for the Sharp Scale Bars. It may be necessary to lower the Damper Bar (depress the Pedal) in order to align the Bar Cord under the hooked portion of the Posts on the two Center Rails.

11. Adjust the Damper Pedal (Shown in Figure 2) to proper playing height. Tighten the hand knob securely to prevent the Upper Pull Rod from slipping. The instrument is now ready for use.

Your new instrument is guaranteed against defects in workmanship and material through normal use. Please use good judgement in selecting your mallets. Use of brass or steel ball mallets will nullify the guarantee.
Do not use Acrylic or Lexan mallets on wood keyboards.

A WORD ABOUT YOUR CASTERS:

Your instrument is equipped with (4) casters that do not use internal sockets in the black aluminum legs for attachment. The casters secure to the leg tube by means of an expandable stem.

The following instructions should be followed for installing and removing the casters. See illustration below.

Note: Make certain that the round, knurled nut at the top of the stem of the caster is tightened against the rubber tube that covers the stem.

The large eight sided nut directly above the ball bearings on the caster controls the diameter of the expandable stem by increasing or decreasing the size of the rubber tubing that covers the stem when the stem is inside the leg tube. Looking at the caster from the bottom, turning the eight sided nut clockwise increases the diameter. Turning the nut counterclockwise decreases the diameter.

TO INSTALL: Slide the stem of the caster all the way into the leg tube. If the stem will not go in, decrease the diameter by grasping the rubber covering the stem in one hand and turning the eight sided nut counterclockwise with the other hand. When the stem is fully inside the tube, **turn the large nut clockwise**, by hand, until it is tight and the stem is secure in the leg. There is no need to over tighten. No tools are required. **(NOTE: If any of the casters ever become loose or fall out, follow the installation procedure and turn large nut on caster a couple extra turns until tight.)**

TO REMOVE: Turn the large nut counterclockwise, by hand, until the caster stem can be pulled out of the leg tube. Again, no tools are required.

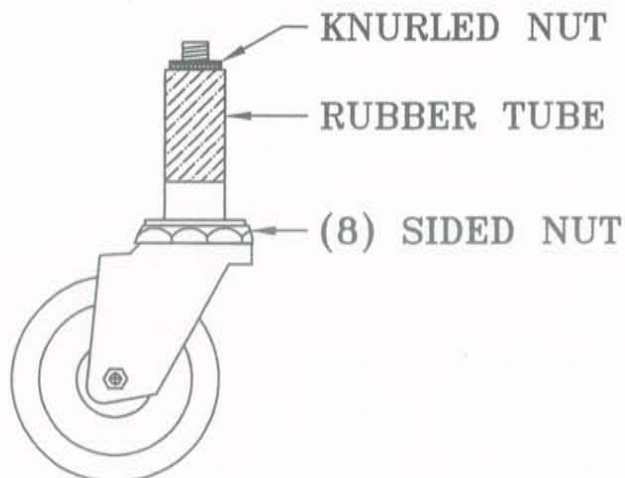

Your M44 is equipped with a three speed pulley.



SLOW POSITION



MEDIUM POSITION

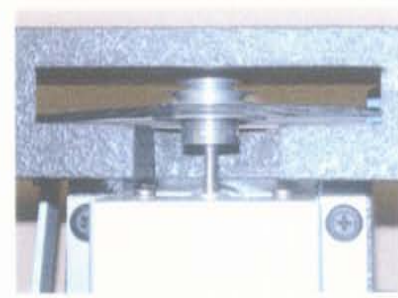

FAST POSITION

- A. Slip the Belt around the desired Pulley on the motor.
- B. Slip Belt around the outside of the pin.
- C. Attach the Belt around the pulley on the PLAIN Scale Resonator.
- D. Stretch the Belt toward, then around the SHARP Scale Resonator Pulley.

IMPORTANT

When the Vibe Motor is not being used, Pulsator Discs in Resonators should be set at a 45-degree angle for maximum resonance.

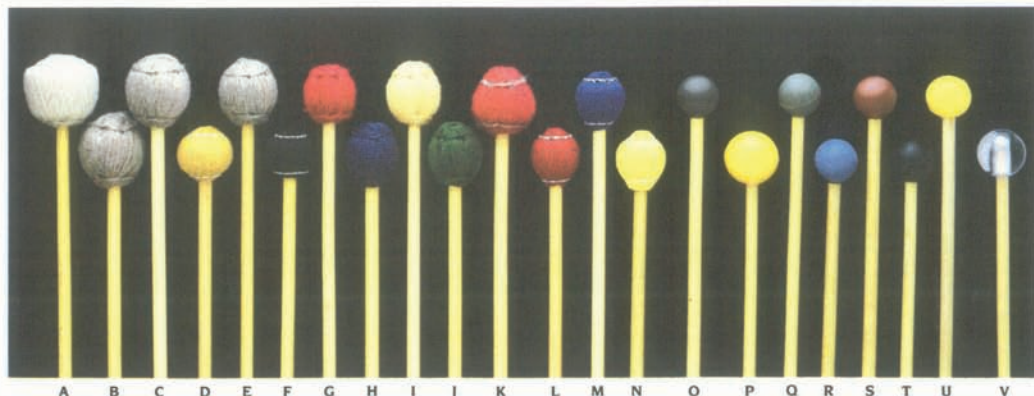

Rattan Handle Mallets

These high quality mallets feature select rattan handles. Rubber heads are hardness-graduated for a wide selection of tonal responses. Finest grade cord or yarn is used on covered mallets. Each mallet is carefully matched and balanced for flex, weight, and size. Packed in clear-view vinyl cases. The professional Gary Burton Signature Mallets (M-220, M-221) are crafted to his personal specifications.

Description	Model No.	Description	Model No.
A. Yarn 1 1/8", Very Soft, Natural (M)	M-204	N. Cord 1", Soft, Yellow (V)	M-218
B. Yarn 1 1/8", Very Soft, Gray (M)	M-223	O. Phenolic 1", Hard, Brown (B, X)	M-215
C. Yarn 1 1/8", Soft, Gray (M)	M-210	P. Rubber 1 1/8", Medium Soft, Yellow (M)	M-205
D. Yarn 1 1/8", Medium Hard, Gold (M, V)	M-221	Q. Rubber 1", Hard, Gray (B, X)	M-214
E. Yarn 1 1/8", Soft, Gray (M)	M-209	R. Rubber 1", Medium Hard, Blue (M, B, X)	M-213
F. Yarn 1 1/8", Soft, Black (M, V)	M-220	S. Rubber 1", Medium, Red (M, X)	M-212
G. Yarn 1", Hard, Red (M)	M-206	T. Rubber 1", Medium Soft, Black (M)	M-224
H. Yarn 1", Medium, Blue (M, V)	M-207	U. Rubber 1", Soft, Yellow (M)	M-211
I. Yarn 1", Medium Soft, Yellow (M)	M-208	V. Lexan 1 1/8", Very Hard, Clear (B, X)	M-203
J. Yarn 1", Soft, Green (M)	M-222		
K. Yarn 1", Soft, Red (M)	M-219		
L. Cord 1", Hard, Red (V, X)	M-216		
M. Cord 1", Medium, Blue (V)	M-217		

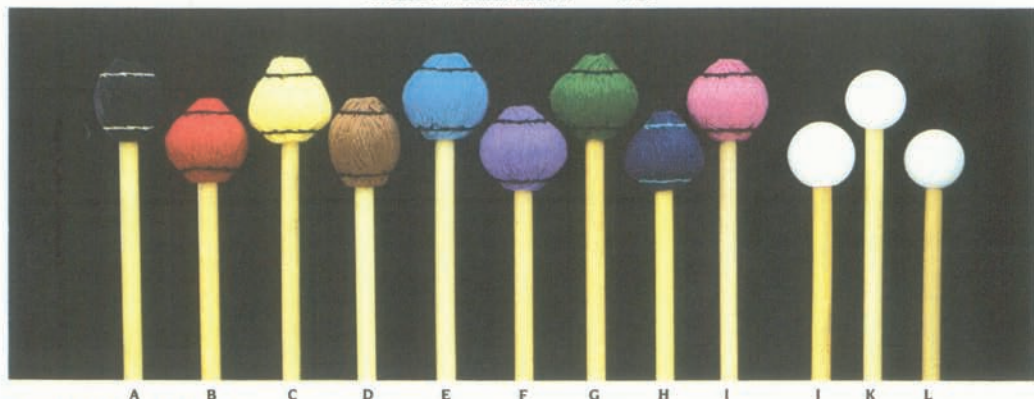

Good Vibes Mallets

Good Vibes are recognized as the world's finest professional mallets. Handles are choice light rattan, carefully selected and matched for size, weight, and flex. Select premium yarn is wound around a solid, specially formulated and shaped rubber core, then carefully hand-stitched. Packed in clear-view vinyl cases.

Description	Model No.	Description	Model No.
A. Yarn 1 1/8", Hard, Black (X)	M-232	G. Yarn 1 1/8", Medium Hard, Green (V)	M-239
B. Yarn 1 1/8", Hard, Red (V)	M-236	H. Yarn 1 1/8", Medium Soft, Navy Blue (M, V)	M-228
C. Yarn 1 1/8", Medium Hard, Yellow (M, V)	M-229	I. Yarn 1 1/8", Medium Soft, Pink (V)	M-233
D. Yarn 1 1/8", Medium Hard, Brown (X)	M-231	J. Poly 1 1/8", Medium Hard, White (B, X)	M-226
E. Yarn 1 1/8", Medium Hard, Royal Blue (V)	M-235	K. Poly 1", Medium Hard, White (B, X)	M-225
F. Yarn 1 1/8", Medium Hard, Violet (V)	M-237	L. Nylon 1", Hard, White (B, X)	M-227

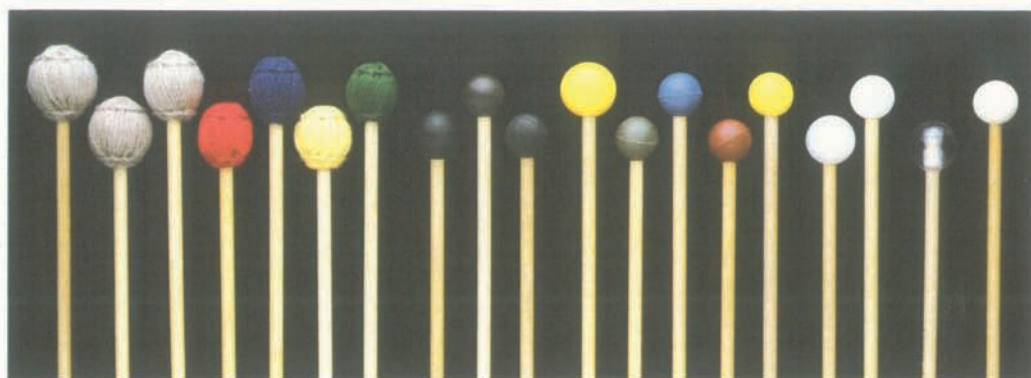

Birch Handle Mallets

For the mallet player who wants a straight, but firmer, wood handle mallet. Precision matched for balance, these mallets come with rubber, plastic, or yarn heads. Packaged in clear vinyl cases.

Description	Model No.	
A. Yarn 1 1/8". Very Soft, Gray (M)	M-412	K. Rubber 1 1/8", Medium Soft, Yellow (M)
B. Yarn 1 1/8", Soft, Gray (M)	M-410	L. Rubber 1", Hard, Gray (B, X)
C. Yarn 1 1/8", Soft, Gray (M)	M-409	M. Rubber 1", Medium Hard, Blue (M, B, X)
D. Yarn 1", Hard, Red (M)	M-406	N. Rubber 1", Medium, Red (M, X)
E. Yarn 1", Medium, Blue (M, V)	M-407	O. Rubber 1", Soft, Yellow (M)
F. Yarn 1", Medium Soft, Yellow (M)	M-408	P. Poly 1 1/8", Medium Hard, White (B, X)
G. Yarn 1", Soft, Green (M)	M-411	Q. Poly 1", Medium Hard, White (B, X)
H. Phenolic 1 1/8", Hard, Black (B, X)	M-424	R. Lexan 1 1/8", Very Hard, Clear (B, X)
I. Phenolic 1", Hard, Brown (B, X)	M-405	S. Nylon 1", Hard, White (B, X)
J. Phenolic 1", Hard, Black (B, X)	M-428	

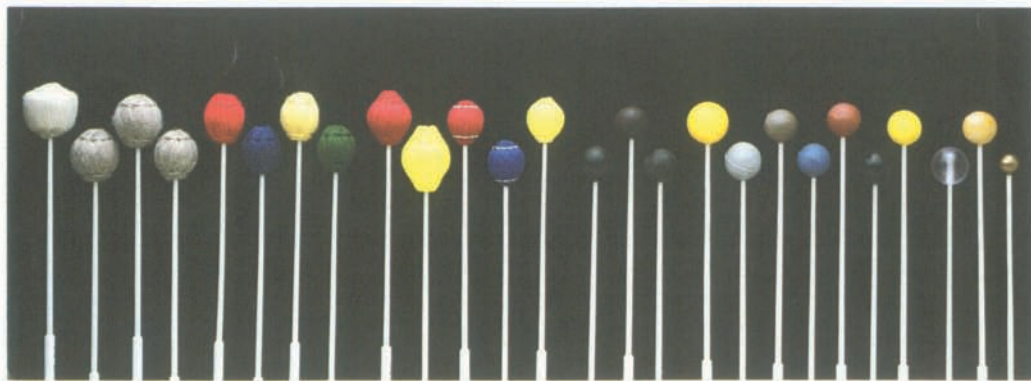

Two-Step Handle Mallets

Musser's exclusive two-step fiberglass handles are thick near the end for well-balanced handling and thin near the head for strong striking force. Excellent flexibility, yet highly warp resistant. All mallets precision matched for balance. Available in a wide variety of graduated rubber, plastic, metal, and wood balls as well as cord or yarn-covered balls. Packaged in clear vinyl cases.

Description	Model No.	
A. Yarn 1 1/8". Soft, Natural (M)	M-19	P. Phenolic 1", Hard, Black (B, X)
B. Yarn 1 1/8", Very Soft, Gray (M)	M-12	Q. Rubber 1 1/8", Medium Soft, Yellow (M)
C. Yarn 1 1/8", Soft, Gray (M)	M-10	R. Rubber 1 1/8", Hard, Gray (B, X)
D. Yarn 1 1/8", Soft, Gray (M)	M-9	S. Rubber 1", Hard, Gray (B, X)
E. Yarn 1", Hard, Red (M)	M-6	T. Rubber 1", Medium Hard, Blue (M, B, X)
F. Yarn 1", Medium, Blue (M, V)	M-7	U. Rubber 1", Medium, Red (M, X)
G. Yarn 1", Medium Soft, Yellow (M)	M-8	V. Rubber 1", Medium Soft, Black (M)
H. Yarn 1", Soft, Green (M)	M-11	W. Rubber 1", Soft, Yellow (M)
I. Cord 1 1/8", Medium Hard, Red (M, V)	M-27	X. Lexan 1 1/8", Very Hard, Clear (B, X)
J. Cord 1 1/8", Medium, Yellow (M, V)	M-29	Y. Wood 1", Hard, Maple ()
K. Cord 1", Hard, Red (V, X)	M-16	Z. Brass 3/8", Very Hard, Gold (Steel Bells)
L. Cord 1", Medium, Blue (V)	M-17	
M. Cord 1", Soft, Yellow (V)	M-18	
N. Phenolic 1 1/8", Hard, Black (B, X)	M-24	
O. Phenolic 1", Hard, Brown (B, X)	M-5	

USAGE CODE: V = Vibraphone, M = Marimba, X = Xylophone, B = Bells

HOW TO OBTAIN MALLETS, REPLACEMENT PARTS, OR SERVICE

CONTACT YOUR LOCAL LUDWIG/MUSSER AUTHORIZED DEALER. THE DEALER WILL CONTACT OUR DEALER SERVICE DEPARTMENT TO ASSIST YOU.

IF YOU CANNOT LOCATE AN AUTHORIZED DEALER, PLEASE CALL 574-522-1675 AND ASK FOR DEALER SERVICE.

VISIT OUR LUDWIG/MUSSER
WEB SITE ON THE INTERNET
<http://www.ludwig-drums.com>

Products

- Drum Outfits
- Snare Drums
- Marching Percussion
- Concert Percussion
- Educational Percussion
- Hardware

Promotional Items

- Catalogs/Brochures
- Posters
- Wearable Items

What's New

- New Product Press Releases
- Percussion Events

Artists/Clinicians

- Drum Outfits
- Marching
- Mallet Instrument
- Total Percussion

Dealers

- USA by State
- Canada by Province
- International Distributors